

\\0server\user folders\Town Projects\AutoCAD Projects\Non-Town Wide\Details\Storm\ST-13\StormSewerExistingManhole.dwg

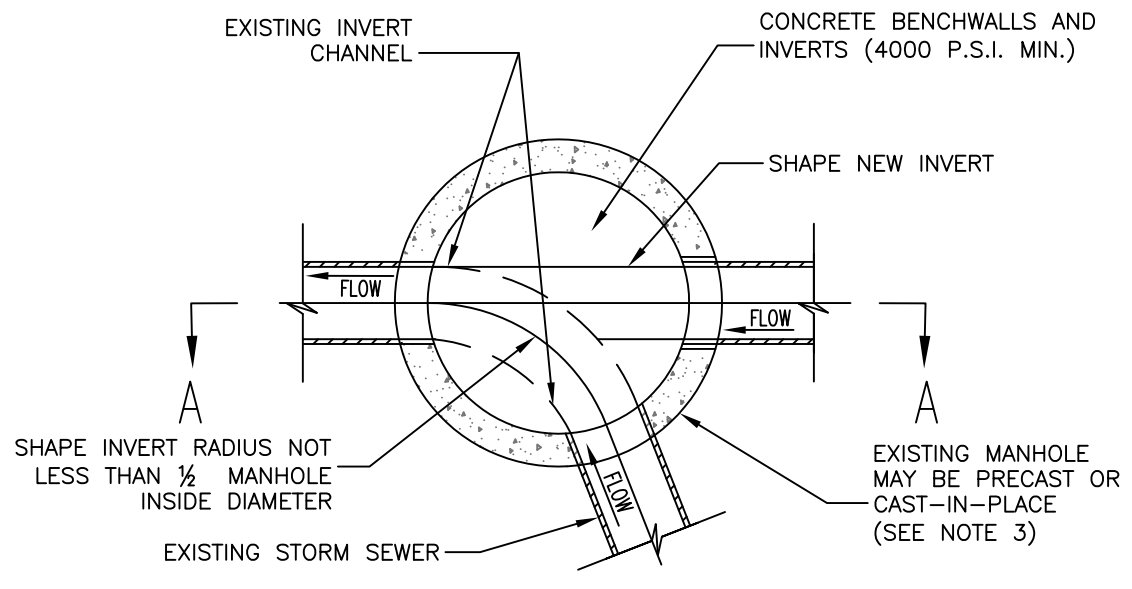

SECTION PLAN

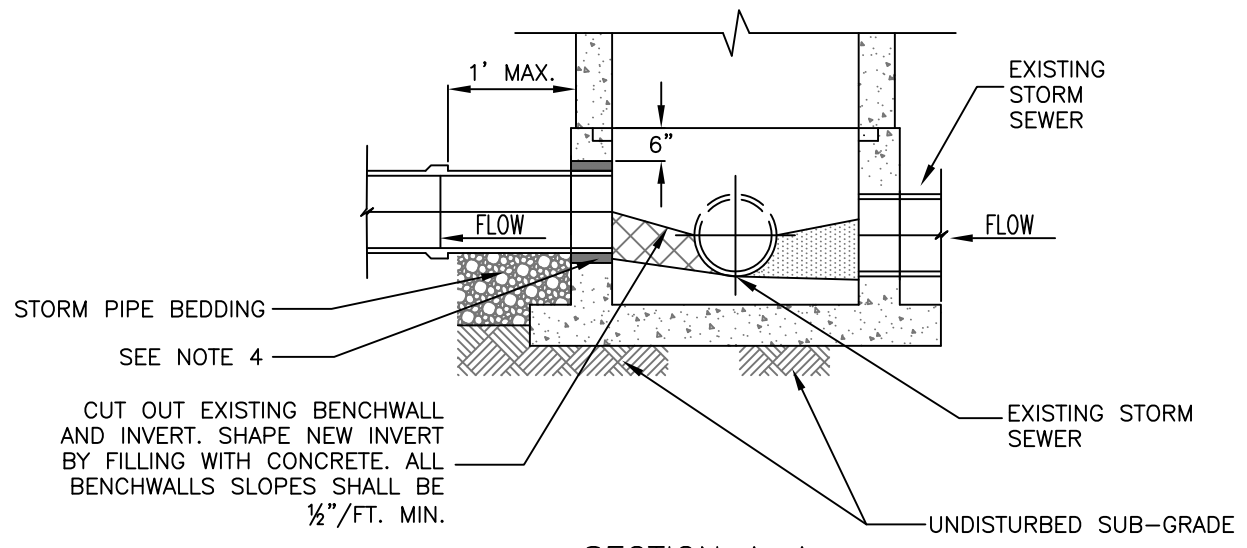

SECTION A-A

NOTES:

1. THE CROWN OF THE NEW SEWER SHALL NOT BE CONSTRUCTED LOWER THAN THE CROWN OF THE EXISTING MAIN SEWER. THE INVERT OF THE NEW SEWER SHALL BE CONSTRUCTED AT LEAST 3" ABOVE THE EXISTING MAIN SEWER INVERT.
2. EXISTING MANHOLE STRUCTURE SHALL BE SUFFICIENTLY BRACED AND PROTECTED TO PREVENT ANY SHIFTING OR DAMAGE TO THE MANHOLE.
3. THE EXISTING MANHOLE BASE MAY BE ROUND OR CAST-IN-PLACE CONCRETE DEPENDING ON HOW THE MANHOLE WAS CONSTRUCTED.
4. CORE DIAMETER HOLE TO ACCOMMODATE NEW STORM SEWER PIPE EMBEDDED INTO MANHOLE AND SEALED WITH NON-SHRINK GROUT OR APPROVED EQUAL. NO IMPACT DEVICES WILL BE ALLOWED TO BE USED FOR MAKING HOLES.
5. THE INTERIOR OF STORM MANHOLE BASE SECTION TO BE 12" MIN. ABOVE THE HIGHEST PIPE. THE SMOOTH INVERT AND BENCHWALL SHALL BE CAST-IN-PLACE CONCRETE (4000 P.S.I. MIN.) ALL OTHER SURFACES SHALL HAVE 2 COATS KOPPERS SUPER SERVICE BLACK.
6. PIPE ENTERING INTO STORM MANHOLE SHALL NOT EXCEED 90 DEGREES ALIGNMENT AGAINST EXISTING STORM SEWER MAIN FLOW.
7. CORED OPENINGS IN MANHOLE RISER SECTIONS SHALL BE NOT LESS THAN 6" FROM A RISER JOINT.
8. THE TOWN MUST BE NOTIFIED 48 HOURS IN ADVANCE OF CONSTRUCTION FOR INSPECTION OF CONNECTION.



TOWN OF HENRIETTA

STORM SEWER CONNECTION TO EXISTING MANHOLE	
SCALE: N.T.S.	ST-13
DATE: 11/15/2011	