

NOTES:

1. NYLON PULL CORD WITH 250# BREAKING STRENGTH TO BE INSTALLED BY CONTRACTOR.
2. CONDUIT TO BE INSTALLED IN TRENCH WITH SMOOTH GRADE. A MAX. OF 3-90° BENDS AND SHALL NOT BE "SNAKED" ALONG TRENCH. THE CONTRACTOR IS TO MANDREL CONDUIT AFTER INSTALLATION WITH BALL MANDREL 70% DIA. OF CONDUIT.
3. THE JOINING OF CONDUIT TO R.G.&E. FACILITIES SHALL BE AS DIRECTED BY THE UTILITY.
4. CONDUIT SHALL EXTEND A MIN. OF 2' BEYOND THE DEDICATED R.O.W. OR TOWN UTILITY EASEMENT, WHICH EVER IS GREATER.
5. LIGHT POLE SHALL BE 18' DIRECT BURIAL BLACK FIBERGLASS LIGHT POLE WITH A SMOOTH FINISH AS MANUFACTURED BY NORTH PACIFIC COMPOSITER (OR APPROVED EQUAL).

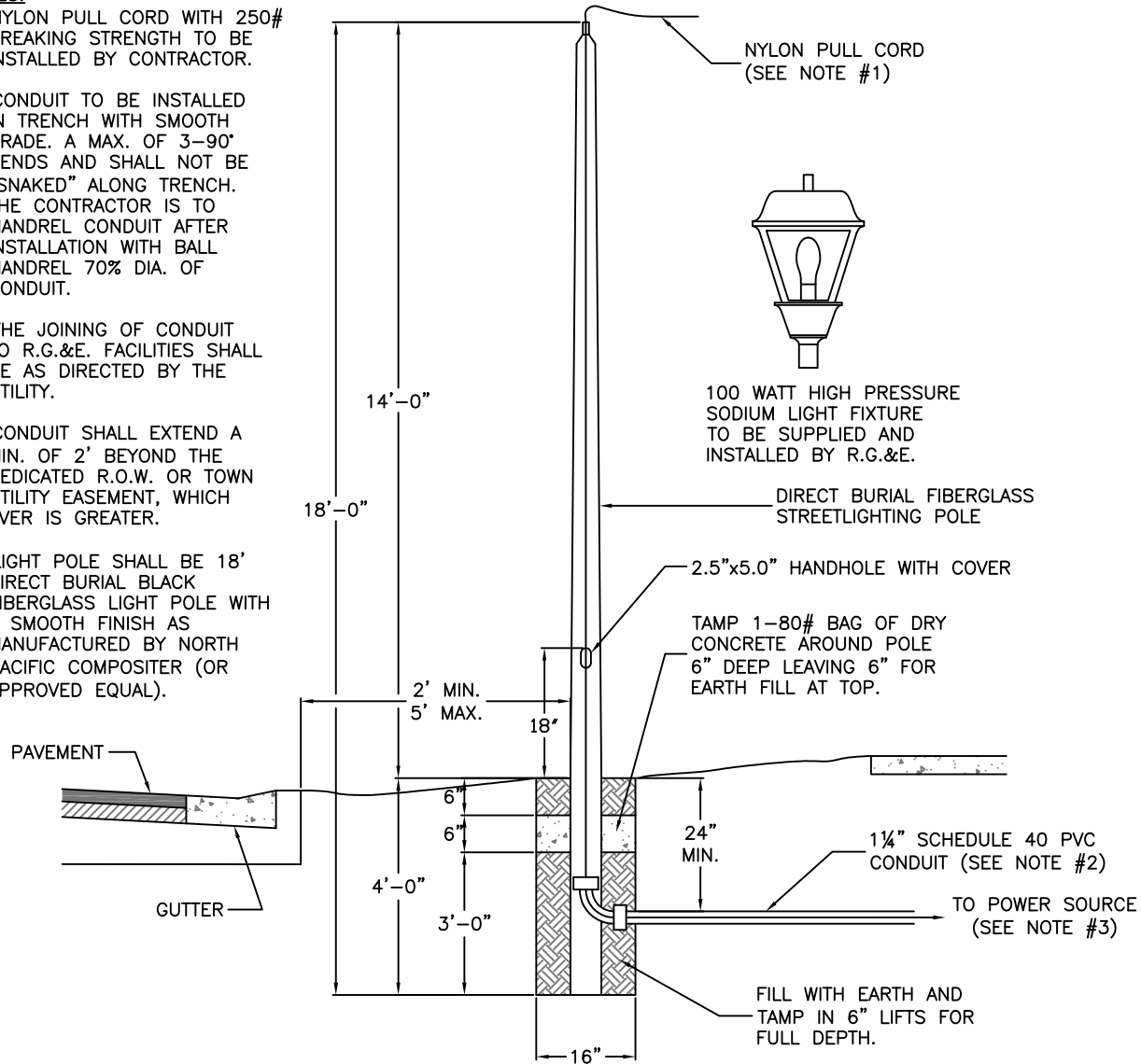
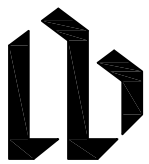

 TOWN OF HENRIETTA	TYPICAL STREET LIGHT POLE & CONDUIT INSTALLATION	
	SCALE: N.T.S.	M-3
DATE: 11/10/2011		