

TOWN OF HENRIETTA  
**Landscape Guidelines**  
STANDARDS FOR DEVELOPMENT

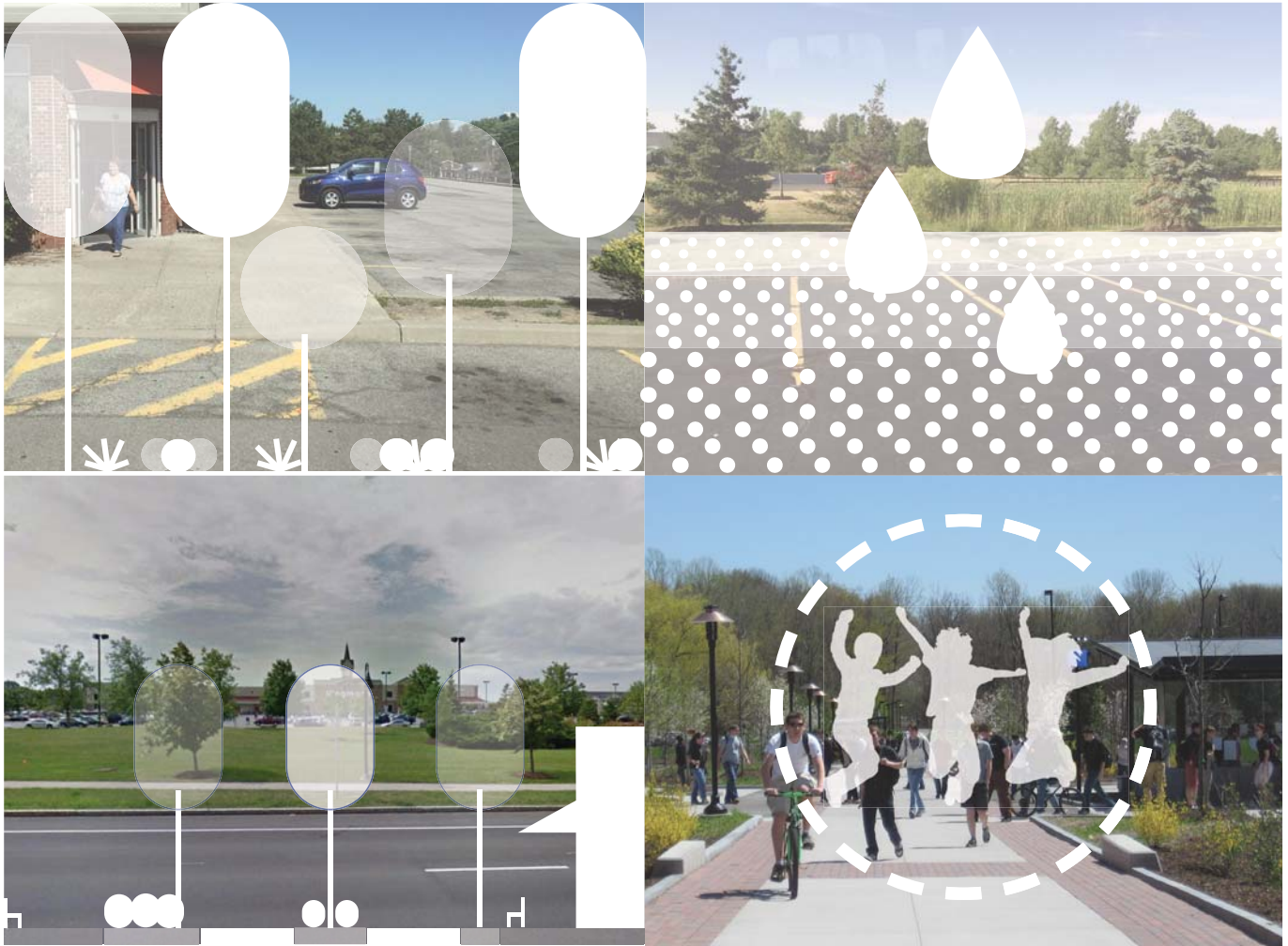

PREPARED FOR: ENGINEERING & PLANNING DEPARTMENT - HENRIETTA, NY  
PREPARED BY: BARTON & LOGUIDICE, DPC  
JULY 2019



## TABLE OF CONTENTS

### **1.0 INTRODUCTION** **4**

---

- A. New Development + Redevelopment + Conservation
- B. High Performance Landscapes
- C. Vision

### **2.0 LANDSCAPE GUIDELINES** **6**

---

- A. Guideline Purpose & Intent
- B. Performance Metrics
- C. Planning Board Application
- D. Related Documents
- E. Amendments

**2.1 PUBLIC HEALTH & WELL-BEING** **10**

**2.2 SOILS** **12**

**2.3 PLANTINGS** **15**

**2.4 STORMWATER MANAGEMENT** **22**

**2.5 MATERIALS** **27**

**2.6 CONNECTIVITY, TRANSITIONS, & BUFFERS** **30**

**2.7 MAINTENANCE** **32**

### **3.0 LANDSCAPE SCENARIOS** **36**

---

- A. Site Guide
- B. Landscape Scenarios
- C. Surface Parking
- D. Office and/or Multi-Use Complexes
- E. Streetscape



## **APPENDICES**

### **APPENDIX A. QUICK REFERENCE GUIDE**

### **APPENDIX B. PLANT LISTS**

- Native Species List
- Invasive Species List
- Recommended Plant Lists

### **APPENDIX C. ADVISORY COMMITTEE INVOLVEMENT**

### **APPENDIX D. SITE CONTEXT & TOWN DOCUMENT ANALYSIS**

- Henrietta Landscape Tour
- Document Analysis & List

### **APPENDIX E. MAINTENANCE ACTIVITIES**

- Onondaga County Save the Rain Program

### **APPENDIX F. ASSESSMENT & INSPECTION FORMS**

### **APPENDIX G. REFERENCE DOCUMENTS**

- Standard Town Details
- NYS Standards and Specifications for Erosion and Sediment Control

### **APPENDIX H. GLOSSARY\***

- \*Key Words Defined in Glossary*



# 1.0 INTRODUCTION

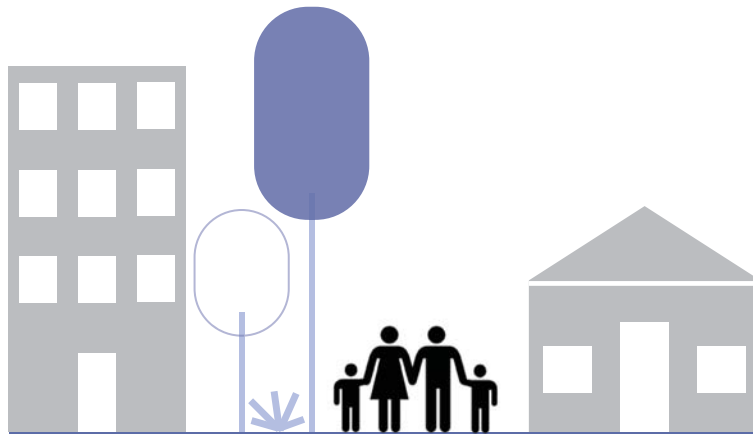

## A. NEW DEVELOPMENT + REDEVELOPMENT + CONSERVATION

The Town of Henrietta, located in Monroe County, is now entering a challenging and exciting stage of growth. The Town has robust open space and natural resources that should be conserved, at the same time increasing the tax base with appropriate new development. Some commercial areas are “aging out” and offer opportunities for creative redevelopment and adaptive re-use.

Focus on this new economic development strategy opens opportunities to create standards that reinforce Henrietta’s vision of, “a suburban and rural town working to maintain a balance between appropriate development and the preservation of its community character and quality of life” (Comprehensive Plan 2011). The Landscape Guidelines Update can help support the practical integration of natural systems into the built environment, and establish an equitable balance point between resource conservation, intelligent economic development, and enhancing community character.

## B. HIGH PERFORMANCE LANDSCAPES

Today, built landscapes are acknowledged as having significant and measurable benefits for stormwater management, biodiversity, energy efficiency, air quality, reduction of greenhouse gases, and public health. Based on the latest research and relevant data, Henrietta has updated and expanded existing landscape guidelines to maximize the benefits of landscapes that are both high-performance and aesthetically pleasing.

All constructed landscapes in Henrietta should be attractive, context sensitive, maintainable, and highly functional. “Landscape performance can be defined as a measure of the effectiveness with which landscape solutions fulfill their intended purpose and contribute to sustainability. No matter how sustainability is defined



- zero carbon, net zero water, biodiversity, quality of life- it cannot be achieved without considering landscape.” (SITES). Updating the Henrietta Landscape Guidelines will help establish sustainable environments that achieve the overall vision of the Town.

## B1. BEST PRACTICE MODELS

The Henrietta Landscape Guidelines Update builds upon local, state, and national standards by referencing national and regional models for best practices including the following:

### **LEED (Leadership In Energy And Environmental Design)**



Administered by the United States Green Building Council, is the most widely used green building rating system in the world. Available for virtually all building, community and home project types, LEED provides a framework to create healthy, highly efficient and cost-saving green buildings. LEED certification is a globally recognized symbol of sustainability achievement for building design and construction, interior design and construction, building operations and maintenance, neighborhood development, homes, and cities and communities.

### **Sites Initiative**



Administered by Green Business Certification, Inc., SITES offers a comprehensive rating system designed to distinguish sustainable landscapes, measure their performance and elevate their value. SITES certification is for development projects located on sites with or without buildings—ranging from national parks to corporate campuses, streetscapes to homes, and more. SITES helps create ecologically resilient communities and benefits the environment, property owners, and local and regional communities and economies.

### **City Of Rochester And Monroe County Green Infrastructure Retrofit Manual**



Funded by NOAA and Sea Grant, the Manual provides guidance on utilizing green infrastructure practices to improve community resiliency and climate adaptation. The Manual draws upon the New York State Department of Environmental Conservation, Stormwater Management Design Manual, and State Pollution Discharge Elimination System to pro-actively develop best management practices to guide the planning, design, implementation, and maintenance of green infrastructure installations.

## C. VISION

The Henrietta Landscape Guideline Update builds upon landscape regulations in the Town Code and other Town plans to foster the creation of landscapes that reflect the core values of Henrietta, including a commitment to the health and well-being of residents, the wise stewardship of natural systems, and a unified aesthetic approach throughout the Town.



# 2.0 LANDSCAPE GUIDELINES

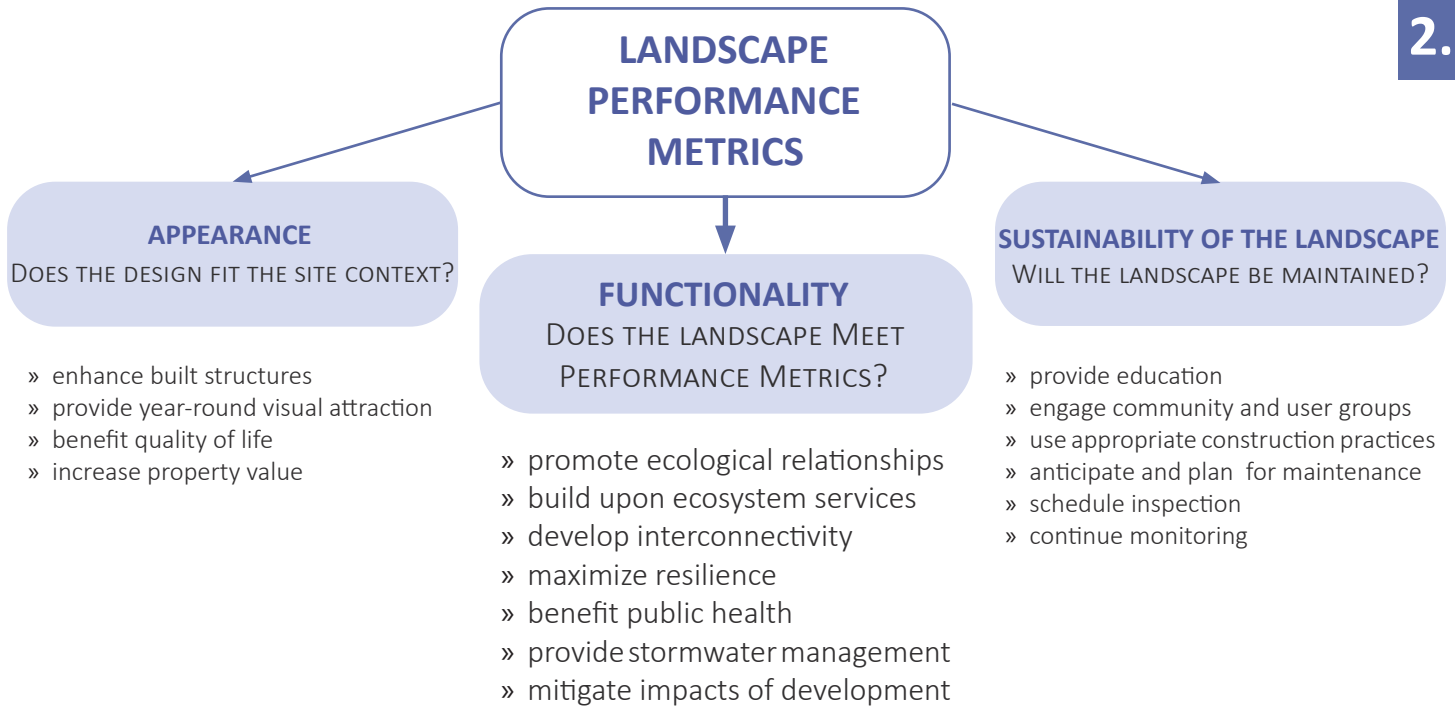

## A. GUIDELINE PURPOSE & INTENT

The Town of Henrietta Landscape Guidelines Update is written to facilitate appropriate landscape installations for development, re-development, and conservation within the Town through landscape performance metrics.

### A1. VOCABULARY

Some of the vocabulary used in the document may be unfamiliar or specific to the topic. These are defined in the Glossary within [Appendix H](#), and indicated with an asterisk\*.

## B. PERFORMANCE METRICS

The framework for the Henrietta Landscape Guidelines Update reflects a suite of 12 main functions of the landscape that characterize maximum performance. This strategical set of criteria ensures the landscape not only provides visual quality, but also provides services to the community and the environment.

### 1. Improve Public Health & Well-Being

Providing a high quality of life and health to the public through social, mental, and physical means by improving living conditions and further developing the community.

### 2. Improve Air Quality

Trees absorb pollutant gases (nitrogen oxides, ammonia, sulfur dioxide and ozone) and filter particulates out of the air by trapping them on their leaves and bark. Trees also absorb carbon dioxide, removing and storing the carbon while releasing oxygen back into the air.



### **3. Improve Stormwater Quality**

Designing for infiltration, bio-retention, and stormwater intercept through the incorporation of strategically vegetated areas and plantings with efficient uptake. Well-designed and constructed green infrastructure practices can improve water quality and provide a broad spectrum of community benefits.

### **4. Mitigate Stormwater Quantity**

Designing for resiliency by planning for the expectation of flood and storm events. Reducing impermeable surfaces and integrating landscape features that control runoff close to where it falls. Preventing localized drainage issues can reduce winter icing hazards and improve pedestrian safety.

### **5. Provide Microclimate Benefits**

Providing an atmosphere of shade, moisture, and temperature differentiation through the use of overhead trees as canopy or surrounding vegetation improves comfort year-round and encourages pedestrian mobility.

### **6. Reduce Impacts of Urban Heat Island**

Reducing the absorption of UV rays through reduction of dark colored pavements, impermeable surfaces, and other site materials that cause higher temperatures in concentrated built areas and cities that persist longer into the night than in rural areas. Both roof and non-roof urban heat island effect can be mitigated by high-performance landscapes.

### **7. Increase Property Value**

Provides amenities or qualities that will attract future homeowners, customers, and businesses that positively impact the economy of the site and surrounding areas.

### **8. Promote Safety & Security**

Improving perception and quality of public and private spaces. Research shows that neighborhoods and developments lacking landscaping have higher crime rates than their greener counterparts. Street trees are an effective traffic calming measure, reducing vehicular speeds and improving safety for bicycles and pedestrians.

### **9. Four Season Visual Quality**

Incorporating features and plantings with consideration of form, texture and color in all seasons.

### **10. Increase Energy Efficiency**

Incorporating landscape features to reduce significant effects of weather, such as heating and cooling, as well as harvesting renewable energy to reduce reliance on greenhouse gases and non-renewable resources.

### **11. Improve Habitat Quality**

Incorporating plantings with habitat value, such as pollinator plants, butterfly plants, and bird attracting plants, to benefit the urban ecological environment.



### 12. Promote Biodiversity

Incorporating varied plant species along transitions, corridors, and within developments to allow the landscape to adapt to changing conditions, prevent the spread of disease, and enhance habitat value. This will promote the longevity and resiliency of landscaped areas over time.

## C. PLANNING BOARD APPLICATION

Within each guideline lies a certain level of flexibility, indicated by “**should**” or “**consider**.” This language is meant to describe the requirement of that guideline for every site design, where “should” indicates a priority recommendation, and “consider” indicates a recommendation. While recommendations are not required, they will ease and quicken the process, and potential approval, of site plan review.

Certain site constraints may affect the implementation of particular guidelines. Therefore not all guidelines are included in the quick reference guide. However, it is important to consider the application of these components during site design and planning board review.

### C1. COMPLIANCE

The Landscape Guidelines are supplemental to Henrietta Town Code and applicable State and Federal Regulations. Preparation of an environmental impact statement may be required if the Town finds that proposed development may have significant effects on the environment. See ***§103 of the Henrietta Town Code*** for more information.

## D. RELATED DOCUMENTS

Several Henrietta Town objectives for promoting strategic development can be applied through best practices of landscape design to balance core community values of improving quality of life, economic opportunities, and environmental conservation.

Each of these objectives can be supported by a specific set of landscape functions. The relationship between the expected impact of each landscape function and how it is reflected in the Town of Henrietta Code, Design Guidance for Multiple-Family Dwelling, and 2011 Town of Henrietta Comprehensive Plan Update is represented on the next page.

Cross references to these other Town documents have been cited or referenced in specific sections, but owners, developers and design professionals should familiarize themselves with all Town documents, including Town Code, to fully understand the expectations of landscape development in the Town of Henrietta. The ***City Of Rochester And Monroe County Green Infrastructure Retrofit Manual*** mentioned in the last chapter of this document is another great resource to be familiar with.

## E. AMENDMENTS

While this guide relates to current development, re-development, and conservation within the Town of Henrietta, this document should be updated and reviewed periodically to adjust to the changing demands and needs of the community over time.



## VISION STATEMENT

The purpose of the Landscape Guidelines Update is to bring Henrietta Landscape Guidelines more in line with the latest data-based best practices for landscape design and construction. The Update will merge with existing landscape regulations in the Town code, and add additional layers of design guidance and landscape performance metrics. The intent is to maximize the contribution that landscapes can make to health, sustainability, and economic growth in Henrietta. The Landscape Guidelines Update will foster the creation of landscapes that reflect the core values of Henrietta, including a commitment to the health and well-being of residents, the wise stewardship of natural systems, and a unified aesthetic throughout the Town.

See Figure below and to the right (adapted from the City of Rochester & Monroe County Green Infrastructure Manual) for more information.



## RELATIONSHIP OF LANDSCAPE FUNCTION TO HENRIETTA TOWN GOALS

LANDSCAPE FUNCTION	COMMUNITY OBJECTIVE	Town of Henrietta Code							Design Guidance - Multiple Family Dwelling				2011 Town of Henrietta Comprehensive Plan Update									
		Relation and Transition of Land Uses	Noise Deterrence	Preservation of Character and Form	Tree Planting and Preservation	Provision of Open Space	Use of Landscape Buffers	Define Distinct Visual Points/Destinations	Separation of Roadway Users	Use of Native Plant Materials	Design Landscape to Complement Built Forms	Increase Runoff Infiltration	Importance of Ongoing Maintenance	Unified and Consistent Aesthetic	Improve the Appearance of Commercial Areas	Preserve and Enhance Water Quality	Preserve and Enhance Habitat Value	Promote Quality and Integrity of Natural Ecosystems	Promote Quality and Integrity of Area of Biologic Diversity	Provide a "Pedestrian Friendly" Environment	Heighten Value of Commercial Properties	Use Overlay Districts
Improves Public Health and Well-Being			●		●		●	●			●	●	●		●		●	●	●		●	
Reduces Air Pollution					●					●							●	●	●			
Improves Stormwater Quality	●			●		●	●	●	●	●	●	●	●		●		●	●		●		
Improves Stormwater Quantity	●			●	●	●	●	●	●	●	●	●	●		●	●	●	●		●		
Microclimate Benefits	●	●	●	●	●	●	●	●	●	●	●	●	●		●	●	●	●	●		●	
Reduces Impacts of Urban Heat Island	●			●	●	●	●	●		●	●	●	●		●	●	●	●	●		●	
Increases Property Value	●	●	●	●	●	●	●	●		●	●	●	●		●	●	●	●	●	●	●	●
Promotes Safety & Security	●	●		●	●	●	●	●		●		●	●						●	●	●	●
Four Season Visual Interest	●	●	●	●	●	●	●			●		●	●			●	●	●	●	●	●	●
Increases Energy Efficiency				●		●		●		●	●	●	●		●		●			●		
Improves Habitat Quality	●		●	●	●	●	●		●	●	●	●			●	●	●	●	●			
Promotes Biodiversity	●	●	●	●	●	●	●		●				●	●	●	●	●	●	●	●	●	●

○ SIGNIFICANT ○ POTENTIAL

## RELATIONSHIP OF LANDSCAPE FUNCTION TO DEVELOPMENT

LANDSCAPE FUNCTION	DEVELOPMENT		
	New Development	Re-Development	Conservation
Improves Public Health and Well-Being			
Reduces Air Pollution			
Improves Stormwater Quality			
Improves Stormwater Quantity			
Microclimate Benefits			
Reduces Impacts of Urban Heat Island			
Increases Property Value			
Promotes Safety & Security			
Four Season Visual Interest			
Increases Energy Efficiency			
Improves Habitat Quality			
Promotes Biodiversity			



LANDSCAPE GUIDELINES

# PUBLIC HEALTH & WELL-BEING

2.1



## A. OVERVIEW

The overall goal for every site design should be to connect amenities, landscape and residents of the Town of Henrietta. “Humans inherently enjoy the diversity of life on Earth... Much of our well being comes from that enjoyment,” (*Biophilia Foundation, 2018*). Incorporating these functional landscape components in site design will provide physical, mental, and health benefits to the residents of the Town of Henrietta and raise awareness on the benefits of high performance landscapes.

## B. PRE-DESIGN SITE ASSESSMENT

Provide an inventory and assessment of existing conditions suitable for informing the development of the site design in regards to opportunities for social, physical, and environmental interaction.

## C. NAVIGATION

The presence of navigational attributes directly affects public well-being, perceived safety and security, as well as the potential property value of the site.

### C1. ACCESSIBILITY

Designate paths with a maximum slope of 5% leading from arrival to destination for ADA accessibility. Design to the maximum extent universal pathways for all user groups. Reference *American Disability Act (ADA) Accessibility Standards*.



## Wayfinding

Incorporate wayfinding\* signage to improve navigation and direct visitors to key nodes, including transportation, landmarks, and historical/cultural features.

## Walkways

Provide continuous sidewalks or equivalent all-weather routes to connect to bordering circulation networks. Install an 8' wide sidewalk on retail or mixed-use blocks (**LEED v4**), and at least a 5' wide sidewalk on other blocks.

## C2. SAFETY & SECURITY

Provide views of nearby streets and landmarks for orientation by using high canopy trees and low plants to preserve sightlines\*. Refer to **Crime Prevention through Environmental Design (CPTED)**.

## C3. LIGHTING

Use energy efficient lighting to reduce environmental impacts. Limiting lighting will reduce light pollution impacts on nocturnal environments. Site lighting that does not directly enhance safety should be minimized.

Refer to **IDA Dark Sky lighting standards at [www.darksky.org](http://www.darksky.org)**.

## QUICK REFERENCE PRIORITIES ✓

### Accessibility

- ✓ Comply with **ADA** standards and concepts of universal design to create accessible path systems that access all facilities on site.

### Safety & Security

- ✓ Enhance sightlines by creating views for orientation and ease of navigation to provide natural surveillance.
- ✓ Use plants above a height of 8' for canopy trees and below a height of 3' for shrubbery along pathways and distinct sightlines.

### Lighting

- ✓ Use LED lighting along pathways intended for early morning, late afternoon, and evening use.



**Navigational Considerations Diagram (CPTED).**



## LANDSCAPE GUIDELINES

# SOILS

## 2.2

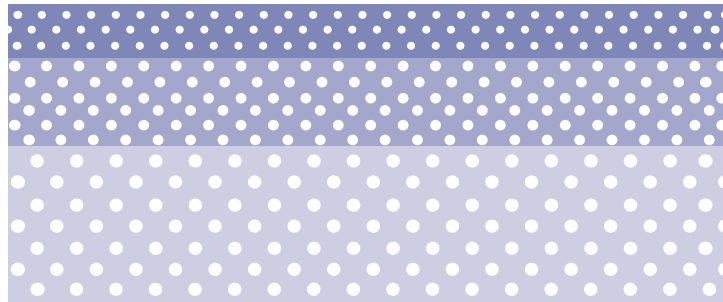

### A. OVERVIEW

Soil is the life-support system of any landscape. Robust soil quality will enable a large number of the landscape functions described on [page 7](#). There are six key roles that soils play in community sustainability, including providing a medium for plant growth, supplying a recycling system for organic wastes and nutrients, modifying the atmosphere by storing carbon, providing a habitat for soil organisms, offering a system for water supply and purification, and providing an engineering medium.

### B. PRE-DESIGN SITE ASSESSMENT

Perform a soil survey as a baseline for stormwater capabilities, and to determine appropriate plant material for the site. Testing should be performed on texture, organic matter, pH, soluble salts, percolation rates, and contamination. This can be done with a mix of a USGS reference map, soil borings, and soil infiltration tests.

#### B1. HEALTHY SOIL

Determine areas of soil to preserve, restore, or replace.

### C. SOIL COMPOSITION

Soils are composed of sand, silt, clay, organic matter, air, water, and microorganisms. Healthy soils have experienced little to no disturbance, no contamination, and exhibit soil horizons, organic matter content, cation exchange\*, and bulk densities. Presence of native plant communities indicate a soil composition that is appropriate for the site. In Henrietta, it is likely that soils will be classified as C or D, meaning they have a high amount of clay in the soil, therefore exhibit low permeability\*, low leaching potential, and high water table.



Refer to *New York State Standards and Specifications for Erosion and Sediment Control 4.52* for more information regarding soil composition, preservation, and restoration.

## C1. TOPSOIL PRESERVATION

Topsoil hosts the majority of biological activity and organic matter that is critical for soil health and processes. Where feasible, salvage healthy topsoil on site. See *Appendix G* for recommendations on soil preservation.

## C2. SOIL PROTECTION ZONES

Identify and protect soils by outlining soil protection zones. Propose physical barriers or indicate these areas in the plan to prohibit traffic and reinforce boundaries on site.

## C3. RESTORATION

Restore disturbed soils in accordance with the *New York State Stormwater Management Design Manual Restoration Requirements*. Recover the original properties and porosity of the soil, which provide a sustainable growth medium for vegetation, to reduce stormwater runoff and increase filtering of pollutants from runoff in accordance with the Manual.

## C4. COMPOST

Use compost to supply organic matter, especially in sandy soils. Compost improves soil and plant health by returning organic matter to the soil in a usable form. Compost can improve the drainage of clay soils, nutrient capacity\*, and moisture retention\*.

Refer to *NYS Standards and Specifications for Erosion and Sediment Control* in *Appendix G* for more information on soil and compost.

## QUICK REFERENCE GUIDE ✓

### Soil Composition

- ✓ Use a minimum of 6" topsoil, 8" preferred.

### Soil Preservation

- ✓ Salvage existing healthy topsoil.
- ✓ Develop a plan to separate topsoil and distinct horizons prior to stockpiling.
- ✓ Seed and mulch stockpiles according to *NYS Standards and Specifications for Erosion and Sediment Control (NYS Standards)*.

### Soil Protection Zones

- ✓ Define soil protection zones.

### Compost

- ✓ Prioritize local sustainable and renewable sources.
- ✓ Use compost that meets *NYS Standards*.

### Soil Restoration

- ✓ Restore disturbed soils by *NYS Standards*.

### Cut/Fill

- ✓ Balance quantities of cut and fill soil to the maximum extent determined feasible.

### Land Formation

- ✓ Relate designed landforms\* to existing local topographic patterns (*SITES*).
- ✓ If not engineered, avoid berms, cut, and fill slopes steeper than 2:1 max, 3:1 preferred.
- ✓ Re-vegetate and re-establish regraded areas within six months after initial disturbance.

### Compaction

- ✓ Require contractor to remove and replace compacted material as a result of construction.

### CU Structural Soils

- ✓ Place priority on using CU Structural soils for street tree plantings and permeable pavement.



## D. CONSTRUCTION CONSIDERATIONS

Construction activities can affect the proposed soil conditions and quality, and therefore the integrity and functionality of the site to drain properly, provide microclimate benefits, and establish an optimal environment for plant material to thrive. Specify approaches to prevent soil compaction, chemical contamination, steep slopes, and to promote the preservation of organic matter and biologic activity.

### D1. CUT/FILL

Reduce the need for earthwork to lessen disturbance on existing flow patterns, soil composition, and topsoil disturbance.

Balance the quantities of cut and fill\* grading. Re-use existing site soils instead of importing or deporting a significant quantity. Preserve site topography and existing drainage patterns\* to the greatest extent possible.

If soil is not able to be re-used on site, stockpile for re-use, which could include use on another local project or transfer to a local farm.

Type of Soil Disturbance	Soil Restoration Requirement		Comments/Examples
No soil disturbance	Restoration not permitted		Preservation of Natural Features
Minimal soil disturbance	Restoration not required		Clearing and grubbing
Areas where topsoil is stripped only - no change in grade	HSG A & B	HSG C & D	Protect area from any ongoing construction activities.
	apply 6 inches of topsoil	Aerate* and apply 6 inches of topsoil	
Areas of cut or fill	HSG A & B	HSG C & D	
	Aerate and apply 6 inches of topsoil	Apply full Soil Restoration **	
Heavy traffic areas on site (especially in a zone 5-25 feet around buildings but not within a 5 foot perimeter around foundation walls)	Apply full Soil Restoration (de-compaction and compost enhancement)		
Areas where Runoff Reduction and/or Infiltration practices are applied	Restoration not required, but may be applied to enhance the reduction specified for appropriate practices.		Keep construction equipment from crossing these areas. To protect newly installed practice from any ongoing construction activities construct a single phase operation fence area
Redevelopment projects	Soil Restoration is required on redevelopment projects in areas where existing impervious area will be converted to pervious area.		

*NYS SMDM Restoration Requirements.*

### D2. LAND FORMATION

Constructed landforms should have a naturalized appearance reflecting regional topography. Avoid straight or rigid graded slopes.

### D3. COMPACTION

Restrict on-site construction activities to reduce compaction from construction vehicles. Define accessible routes by building up soil in layers to either side of the path. Accessible site locations should be determined by where existing soils have already been disturbed or are of the lowest quality on site. Soil composition and texture affects response to compaction. **Sandy soils** are naturally resistant to compaction whereas **clay soils** are much more sensitive to compaction.

### D4. CU STRUCTURAL SOIL

Structural Soil is a medium developed by Cornell University that can be compacted to pavement design and installation requirements while permitting root growth. It is a mixture of gap-graded gravels (made of crushed stone), clay loam, and a hydro-gel stabilizing agent to keep the mixture from separating.





## LANDSCAPE GUIDELINES

# PLANTINGS

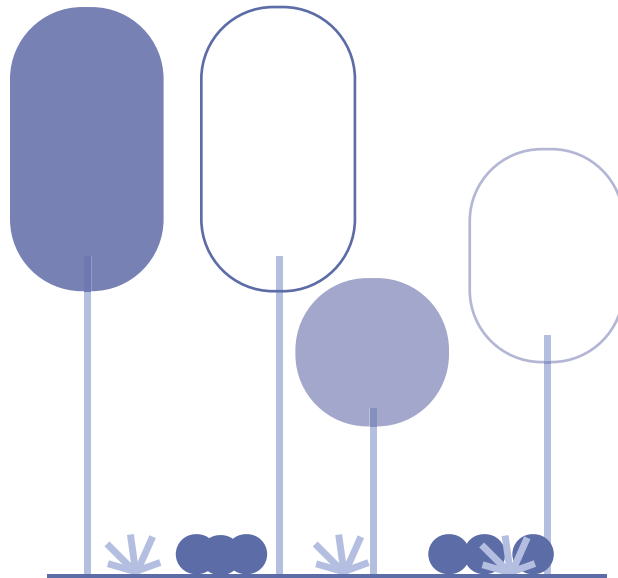

2.3

### A. OVERVIEW

The species, composition, and arrangement of vegetation will significantly impact the ability for the landscape to perform functions. Consider biodiversity and four season visual quality when selecting plant species for the site. The composition of species will impact the quality of habitat created, ability to manage stormwater, as well as safety and security. Diverse structural and species composition will create a habitable ecosystem, substantially increase bio-infiltration, create sightlines, and improve air quality. Placement and arrangement of vegetation and plantings will affect the ability to mitigate effects of the urban heat island, and create microclimate throughout the landscape. Fulfillment of these planting design principles and careful installation will result in landscapes throughout the Town of Henrietta that achieve the desire for high visual and functional quality.

### B. PRE-DESIGN SITE ASSESSMENT

Prior to composing a plant list, it is important to inventory and evaluate what is already present on site and what could be added to enhance qualities of the site. See [Appendix F](#) for a landscape assessment form to be used to assess existing conditions.

#### B1. EXISTING VEGETATION

The process of selecting the appropriate plant species should reflect thorough analysis of site constraints, soils, drainage, and impacts of development. The following considerations should be well documented for ease of application review.

***“Historic designation may be awarded if there is presence of special character, interest, or value by natural landscaping or topography”  
-Henrietta Town Code***



- **Identify, remove, and replace** invasive species\* with native species\*. Comply with NYCRR Part 575 Invasive Species Regulation.
- **Preserve** endangered and threatened species on site. Abide by Threatened and Endangered Species laws and regulations and refer to the *U.S. Fish & Wildlife Service* list of such species.
- **Preserve** exceptional historic, cultural, or ecological value species, excluding prohibited invasive species\*.
- **Preserve** mature, healthy plants. Deciduous trees that are over a 12" DBH and evergreen trees over a 6" DBH (*LEED v4*) and are native demand priority in preservation. This may be subject to change in regards to bat habitat. Woodlands acting as buffers should also be preserved and protected.

As a general guideline, **for each existing tree removed, two trees should be planted in replacement.**

### **Additional Review**

At determination of the Planning Board, the applicant may be recommended to consult and review plans with an arborist professionally certified by the *International Society of Arboriculture (ISA)* or registered with the *American Society for Consulting Arborists (ASCA)*.

## **C. SELECTION PROCESS**

Select species adapted to wetlands, woodlands, woodland edges, grasslands, riparian buffers, successional fields, and/or woodland meadows. While this will inherently produce a diverse composition of plantings, it will also provide salt, drought, and flood tolerance. In addition, select species that demonstrate seasonal color variance, winter appeal, flowering, fruiting, nut/seed, and/or bark texture to provide four season visual interest and added benefits for habitat. *See Appendix B* for recommended plant lists.

*Table 2. Final Plant List Selection Criteria*

	ID	Common Name	Botanical Name	Native (Y/N)	Seasonal Interest	Tolerance Attribute	Size (dbh)	Height (feet)	Caliper (inch)	Cost/Unit	Nursery Source
Reference	-	App. B	App. B	Sect. C, App. B	Sect. C, App. B	Sect. C	Sect. D	Sect. D	Sect. C	Nursery Catalog	Guideline 7.5

Refer to the **Urban Horticulture Institute Site assessment checklist** for more considerations regarding selection. <http://woodyplants.cals.cornell.edu/collections/urbantrees/3a-site-assessment.pdf>

### **C1. NATIVE PLANTING REQUIREMENTS**

Native species are well suited for patterns of drought, disease, and natural predators in the local environment. Therefore, selection of these species will improve vegetative cover while reducing irrigation, pesticide use, and energy needs. *Appendix B* lists NYS native species.

Strategic plantings incorporate a structural mix of native groundcover, perennial, shrub, and tree species to promote biodiversity and resilience. This especially includes consideration of heat and cold tolerances to account for seasonal climate change.

*Promoting pollinator habitats will directly benefit Henrietta, as agriculture is the highest type of land use in the Town.*





## Restoration

Aim to restore native ecological communities, water bodies, or wetlands present during pre-development site conditions in an area equal to or greater than 25% of the development footprint on site, if applicable (*Town of Henrietta Green Space Policy*).

## C2. PLANT COMMUNITIES\*

Design a planting plan that works as a system to maximize the functional and visual qualities of the site. Incorporate botanical diversity through color variation, textures, and seasonal qualities, and consider structural diversity through inclusion of canopy, understory, and groundcover.

Refer to [www.epa.gov/wed/pages/ecoregions.htm](http://www.epa.gov/wed/pages/ecoregions.htm) for more information.

### Cultivar Species

Plant cultivar species\* if better suited than native species in regards to availability, sourcing or site conditions.

### Significant Value Species

For any site with significant historic, cultural, or ecological value species, comply with the U.S. Department of Interior’s standards for historic and cultural landscapes as well as §295-38 of the Henrietta Town Code. This can be found on the DEC Environmental Resources Mapper.

## C3. PLANT SOURCING

Ensure selected plants are well adapted to the soil, moisture, growing, shade, and ecological conditions on site. Use nursery grown, legally harvested, and/or salvaged plant material.

**✓+ Highest Priority** Monroe County.

**✓ Priority** New York State.

**✓- Recommended** Northeast region.

Recommended 25% maximum included in final plant list.

## QUICK REFERENCE GUIDE ✓

### Inventory and Analysis

- ✓ Document invasive, endangered or threatened, and culturally/historically/ecologically significant species on site.
- ✓ Indicate areas of disturbance, demolition, and preservation in the site plan.
- ✓ For each removed tree, plant two trees.

### Native Plantings

- ✓ Complete a final plant list with selection criteria.
- ✓ Specify at least 50% native species in the total plant schedule.
- ✓ Select species classified in Plant Hardiness Zone Regions 5b, 6a, or 6b for heat tolerance, in addition to 2, 3, or 4 for cold tolerance.

### Four Season Visual Interest

- ✓ Provide year-round visual interest in planting plan.

### Biodiversity

- ✓ Plant no more than 10% of any species, no more than 20% of any genus, and no more than 30% of any family (*SITES*).

### Cultivar Species

- ✓ Use cultivar species as appropriate.

### Significant Value Species

- ✓ Preserve and enhance culturally, historically, and/or ecologically significant vegetation.
- ✓ Comply with local, state, and federal standards.

### Plant Sourcing

- ✓ Place preference on locally sourced, nursery grown, and/or sustainably sourced plant material.

### Transplant and Transfer

- ✓ Specify 1.5”-2” caliper for bare root trees.
- ✓ Select low-grow grass seed mixes for lawns.



## D. INSTALLATION

Appropriate installation is critical to a functional landscape. If plant material is selected, established, located, and spaced appropriately, it will develop to maturity to provide optimal urban heat island reduction, as well as air quality and stormwater management improvements.

### D1. TRANSPLANT AND TRANSFER

Select species suited as bare root trees, root production method trees, such as Missouri Gravel Bed trees, or rooted plugs for shrub and perennial transplant, if feasible. They are easier to plant, retain their root system, less expensive, and are more likely to survive.

Refer to the Cornell University Woody Plants Database in [Appendix B](#) to confirm if this is the best method for transport for selected species. Refer to the [American Standard for Nursery Stock](#) for minimum recommendations of transplant sizes and types.

#### Lawn Plantings

Use mixtures of grass seed that require less maintenance to reduce energy use, such as low-grow seed mixes.

### D2. ESTABLISHMENT

To increase the chances of survivability, establish vegetation in the appropriate location and conditions. Inspect plants upon arrival on site, if not during initial selection.

#### Fertilizer, Disease, and Pest Control

Avoid use of synthetic fertilizer. Base Fertilizer applications on soil testing or other appropriate diagnostics. Phosphorus-free fertilizer will reduce pollution of aquatic systems. Reducing or eliminating pesticides and herbicides will benefit pollinator populations and local ecosystems. Utilize Integrated Pest Management (IPM) as an alternative to chemical agents.

## QUICK REFERENCE GUIDE ✓

### Fertilizer

- ✓ Avoid use of synthetic fertilizer, pesticides, insecticides, and herbicides after plant establishment.

### Irrigation

- ✓ Avoid use of irrigation after establishment. If necessary, place preference on drip irrigation, and consider hand watering.

### Protection

- ✓ Install protective fencing and signage near plantings to avoid damage during construction.

### Setbacks

- ✓ Locate small trees at least 15' from building foundations.

### Sun and Wind Mitigation

- ✓ Provide 1 tree for every 10 parking spaces.

### Spacing and Root Volume

- ✓ Space large trees at least 35' apart on center.
- ✓ Space medium trees at least 30' apart on center.
- ✓ Space small trees at least 20' apart on center.
- ✓ Set understory plantings at least 2' from tree trunks (*SITES*).
- ✓ Allot 500 cubic feet minimum root volume for a large to medium sized tree, and 300 cubic feet for a small sized tree or street tree.

### Mulching

- ✓ Avoid mulching past root flare. Expose root flare and set at least 1-2" above ground level.
- ✓ Use 3-4" of mulch around woody plants. and 1-2" of mulch around herbaceous plants.
- ✓ Use locally produced hardwood mulch meeting all project specifications.
- ✓ Avoid dyed and rubber mulch.



## **Irrigation**

Design and install landscapes to reduce or eliminate the need for irrigation. Specify high-quality soils, select native species that are well-adapted to site conditions, plant in the spring or fall, and mulch properly to maintain soil moisture.

## **Protection**

Install protective fencing and signage around existing vegetation to prevent structural damage, compaction of root zone, and soil contamination. Water as needed to mitigate stress during construction. Comply with **§261-9 of the Henrietta Town Code**.

## **D3. LOCATION**

Consider placement, context, and application of plant material. Select high canopy trees and low shrubs with the appropriate amount of density to improve comfort and security.

## **Setbacks**

- Right-of-way lines/private property; utility structures, vents, sewer laterals, major electric lines
- Between existing structures with no basement and green infrastructure
- Utility poles
- Between existing structures and green infrastructure
- Gas Lines
- Water Mains
- Front steps of buildings

See the **GI Retrofit Manual Section 4.3** and **Tree Placement Diagram** below for guidance.

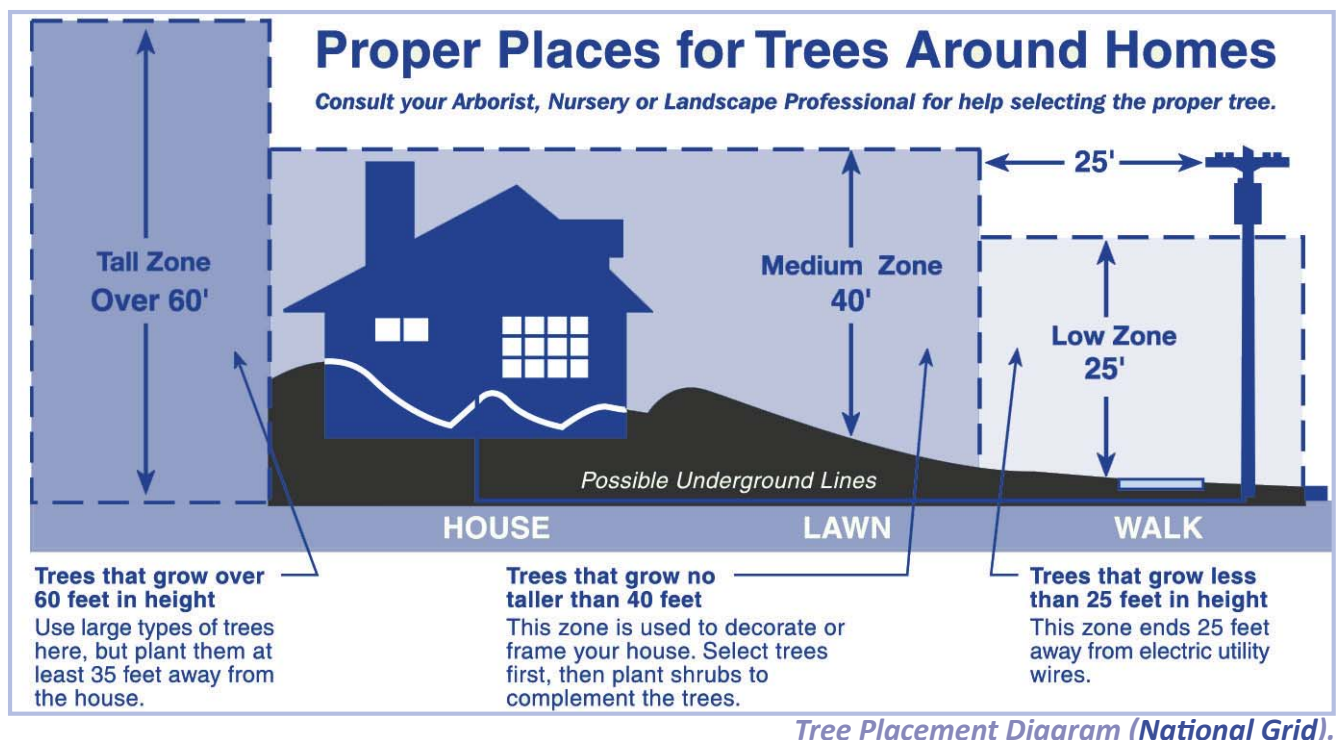



## Sun and Wind Mitigation

Consider sun patterns throughout the day, and integrate a mix of shade opportunities for cooling and interspersed light for sun bathing. Provide areas with wind protection. Aim to shade the paved area on site using plant material that will be fully beneficial in 10 years, vegetative structures fully beneficial within 10 years, and/or shade structures (**LEED v4**).

## D4. ROOT VOLUME

Design for mature root volume allotment and coverage. Selected plants should require minimal pruning and shearing once mature.

### Volume

Provide 500 cubic feet minimum root volume for a large to medium sized tree, and 300 cubic feet for a small sized tree or street tree. If feasible, provide 1000 cubic feet for large mature trees. Install continuous tree trenches to maximize soil rooting volume opportunities. See the figure below for more information.

### Spacing

Provide adequate space to allow each tree to grow to mature size, access light, and consume water.

*“Inadequate soil rooting space can be one of the most important factors in the premature mortality of trees in urban areas”  
-Journal of Arboriculture*

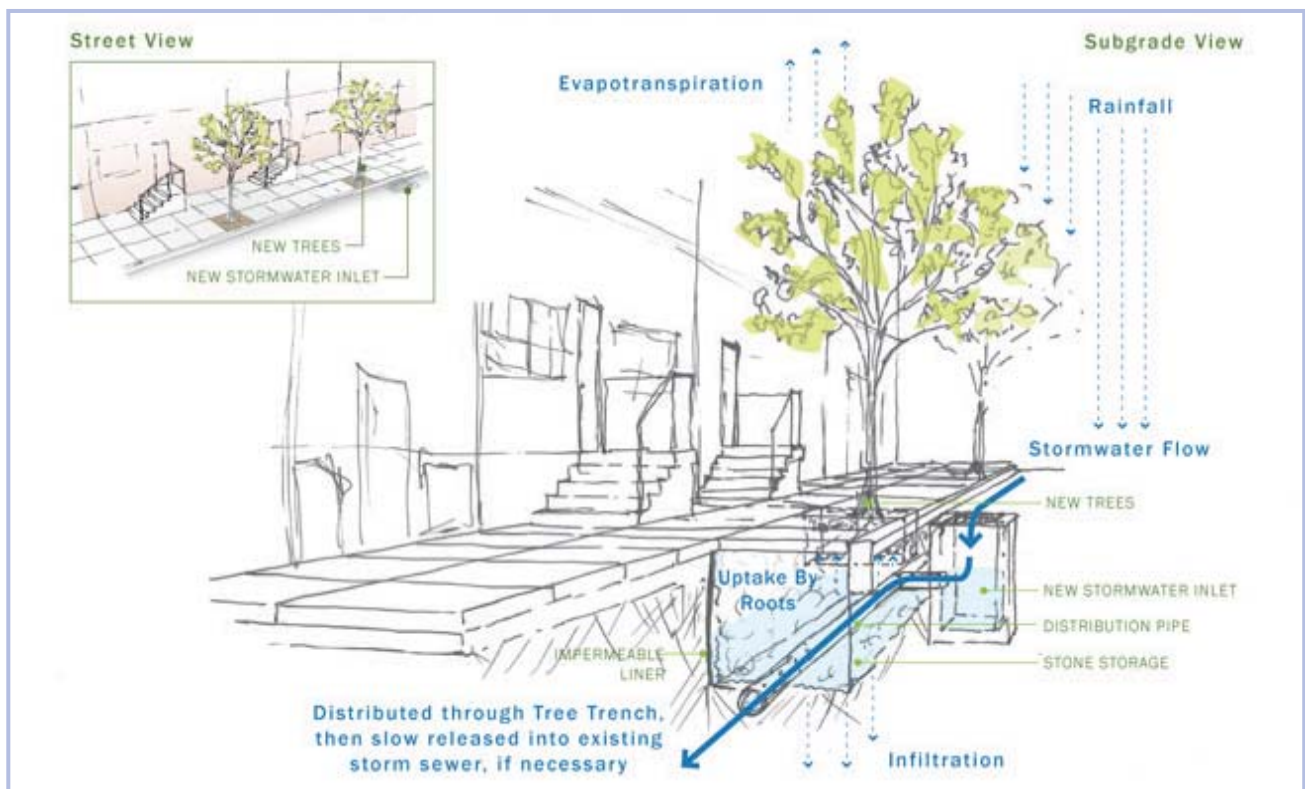

*Continuous Tree Trench (Philadelphia Water Dept).*





### D5. MULCHING

Provide mulching around base of plantings as soon as planted to preserve moisture in soil and prevent erosion. Maintain this area until vegetation has established. Do not mulch past root flare, and never cover the root flare or trunk of a tree, nor the stems of a shrub or perennial. Root flare is the area at the base of the trunk where it broadens to form tree roots.

#### Mulch Composition

Dyed and rubber mulch should be avoided due to potential leaching of chemicals.

See **4.39 NYS Standards and Specifications for Erosion and Sediment Control** in **Appendix G**.

## E. EDUCATION

Interpretive and educational panels are encouraged to mark historic, cultural, and/or ecological significance.

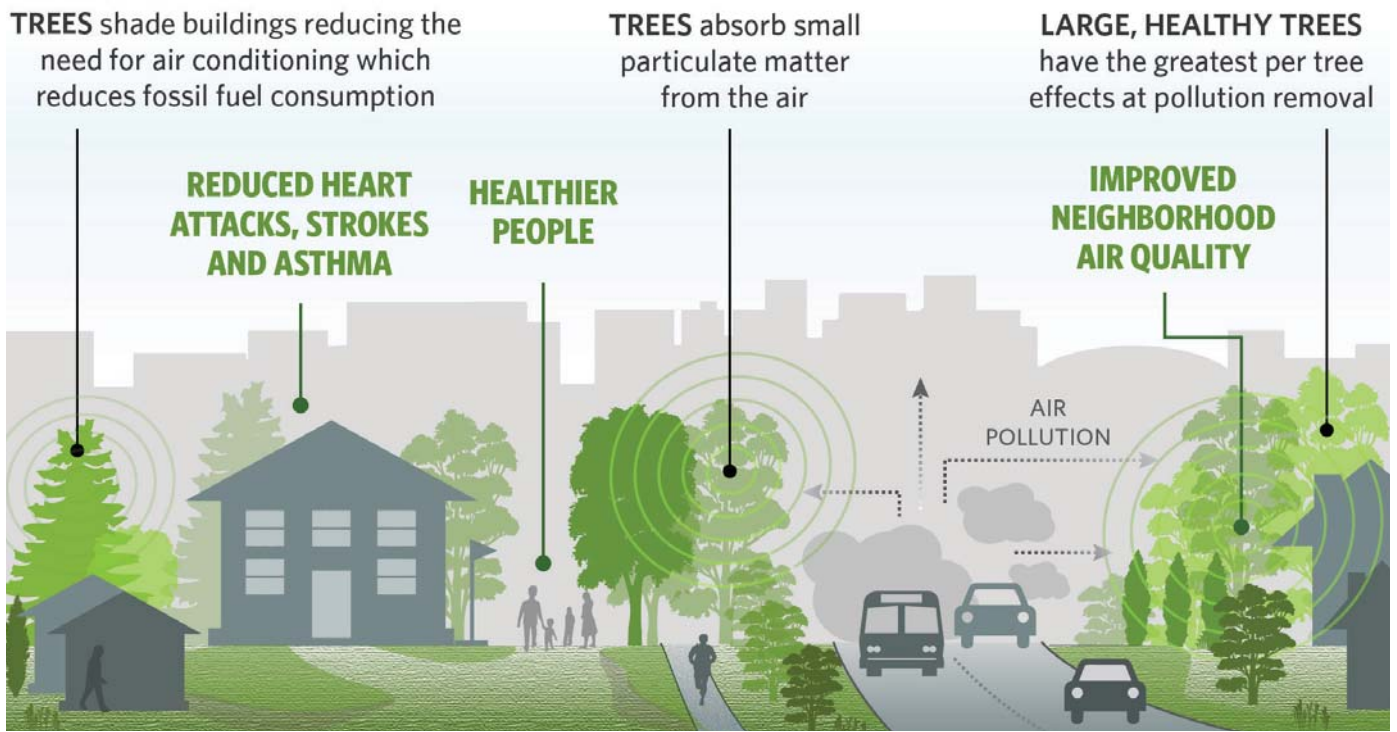

*Importance of Trees (GreenBlue Urban).*

## F. LAND BANK

A land bank program could be developed to mitigate site development unable to meet vegetation & planting criteria, deemed as a result of the planning board review, and supported by SEQRA documentation. This development would compensate by transferring an equivalent amount of habitat or ecosystem disturbed on site to publicly owned land to build upon its natural resource coverage and quality. This compensation is a last resort to mitigate site impacts of development.

## G. LANDSCAPE SCENARIOS

Each site design should meet a certain set of criteria beyond these general guidelines. This varies in regards to appropriate native species selection, cultivar species selection, and species composition\*.



LANDSCAPE GUIDELINES

# STORMWATER MANAGEMENT



2.4

## A. OVERVIEW

Stormwater management\* is essential for protecting water quality, reducing flooding, protecting property, and preserving watersheds. The New York State Department of Environmental Conservation (NYSDEC) establishes requirements for stormwater management. In addition, the Town of Henrietta encourages the consideration of stormwater run-off as a valuable resource. Creative applications of green infrastructure practices are encouraged to meet stormwater regulations and provide the maximum co-benefits for the community.

## B. EXISTING DOCUMENTS

Several documents offer guidance and state regulations for stormwater design.

### B1. COMPLIANCE

**New York State Stormwater Management Design Manual**, enforced by the NYSDEC, provides details regarding size, design, selection and location of stormwater practices to achieve State stormwater performance standards.

**New York Standards and Specifications for Erosion and Sediment Control**, recently updated in 2016 by the NYSDEC, provides guidance for the selection, design, and implementation of practices that prevent erosion and promote sediment control.

**State Pollutant Discharge Elimination System (SPDES) General Permit for Stormwater Discharges from Construction Activity**, a federal program administered by the NYSDEC, should be followed for construction activities implementing design that involves disturbance on more than one acre.



**Stormwater Pollution Prevention Plan (SWPPP)**, created by the NYSDEC, specifies criteria to reduce the impacts of runoff on sites with environmentally sensitive features.

**§236 of the Henrietta Town Code**, outlining general design and performance criteria for stormwater design, provides state regulations and town requirements for the performance and maintenance of stormwater infrastructure.

## B2. GUIDANCE

Several organizations also offer guidance regarding best practices for stormwater design.

**Better Site Design**, created by the NYSDEC in 2008 provides best practices of on site design components of conservation and stormwater design. [http://www.dec.ny.gov/docs/water\\_pdf/bsdcomplete.pdf](http://www.dec.ny.gov/docs/water_pdf/bsdcomplete.pdf)

**Community Solutions for Stormwater Management: A Guide for Voluntary Long-Term Planning**, written by the United States Environmental Protection Agency (EPA), provides the framework to promote stormwater management practices through planning policy and regulation.

**Monroe County Stormwater Coalition**, a group formed as part of the Stormwater Phase II Program as a component of the 1972 Clean Water Act, is dedicated to promote high water quality with the focus on integration into municipalities in Monroe County by ensuring stormwater design complies with state and federal standards.

**Green Infrastructure Municipal Handbook**, written by the Environmental Protection Agency (EPA), provides guidance to local governments regarding basic standards and expectations for green infrastructure system implementation, including funding, retrofit policies, green streets, rainwater harvest, and incentives.

**Green Infrastructure Planning Design Guidelines**, created by the Genesee/Finger Lakes Regional Planning Council, provides overview and guidance for regional green infrastructure practices, including application and implementation planning techniques.

**Monroe County City of Rochester Green Infrastructure Retrofit Manual**, created by Monroe County, provides guidance towards green infrastructure installations in retrofit and redevelopment settings.

**Wetland Delineation Manual**, designed by the Army Corps of Engineers, provides specifications and guidance regarding soils, vegetation, and hydrology criteria used to delineate wetlands.

## C. PRE-DESIGN SITE ASSESSMENT

Analyze and calculate the amount and direction of runoff before considering what stormwater practices are appropriate on site and where they should be located in the **SWPPP**. This should include information regarding on-site infiltration, off-site infiltration, potential pollutants of concern, circulation, flow, peak flow, and permeable surfacing.



## C1. LOCAL & REGIONAL HYDROLOGY

Major Watershed: Genesee, Nine Mile  
Regional Average Rainfall: Annual & Monthly  
Site: Sheet flow patterns, swales, adjacent site flow, and soil composition (mainly type C&D)

## D. MAXIMIZING ON-SITE DRAINAGE

Aim to exceed quantity and quality of infiltration beyond baseline New York State standards for stormwater. Refer to **§A300 of the Henrietta Town Code** and <https://rrstormwater.com/town-henrietta> for more information.

### D1. DRAINAGE REQUIREMENTS

Design to capture the maximum amount of site runoff from driveways, sidewalks, rooftops, parking lots, and landscapes. See **part B of Henrietta Town Code §236-30**.

#### Peak Flow Conditions

Design stormwater practices to mitigate peak flow predictions for the 100 year storm in New York State. It is recommended by the NYS DEC to use the **Extreme Precipitation in New York & New England** interactive web tool as baseline 100-year storm data to design for the 24 hour anticipated peak flow during extreme rainfall conditions. However, according to **SITES**, best stormwater practices should be designed to account for the 80th to 95th percentile event.

#### Special Consideration: Oversight

Review may be required by the Town Board of the Town Drainage Ordinance to oversee drainage plans and ensure proper drainage control measures are in place.

### D2. GREEN INFRASTRUCTURE

Incorporate green infrastructure\* practices, especially if runoff is flowing off-site. Examples of these practices include bio-swales, rain

## QUICK REFERENCE GUIDE ✓

### Existing Documents

- ✓ Comply with **NYS** and **Town of Henrietta** laws and regulations for stormwater design.

### Drainage

- ✓ Maintain local natural drainage patterns.
- ✓ Exceed existing on-site infiltration quantity by at least 5% overall; if determined feasible.
- ✓ Prohibit untreated stormwater discharge into on or off-site wetlands or waterbodies.
- ✓ Avoid standing water for more than three days to reduce mosquito breeding.

### Special Consideration: Oversight

- ✓ Comply with **Henrietta Town Code §A300**, miscellaneous requirements.

### Design Storm

- ✓ Design for the 24 hour anticipated peak flow 100-year storm conditions using the Extreme Precipitation in New York & New England interactive web tool (**NYSDEC**).

### Surface Composition

- ✓ Concentrate permeable coverage at designated low points and drainage areas. Avoid fragmentation of permeable cover.

### Green Infrastructure

- ✓ Reduce impermeable surfaces to the greatest extent possible.
- ✓ Locate bio-retention at least 10' from building foundations, if determined feasible. If not, use an impermeable liner to protect the building foundation.
- ✓ Select and apply appropriate green infrastructure practices, based on existing and proposed site conditions.





gardens, constructed wetlands, riparian buffers, green roofs, green walls, rainwater harvest systems, and bio-retention cells. In all cases, maximum extent should mean the site design strives to provide high quality stormwater design that exceeds Town and New York State baseline requirements.

### **Soil Structure**

Use recommended soil media for adequate drainage in bio-retention areas described below:

- 0% Material >4.76 mm
- <5% Very Coarse Sand/Gravel 2.0-4.76 mm
- 60-85% Sand 0.42-2.0 mm
- <20% Silt 0.074-.42 mm
- <5% Clay <0.074 mm

See the [GI Retrofit Manual Section 3.1.3](#) and the [University of New Hampshire Stormwater Center](#) for more information.

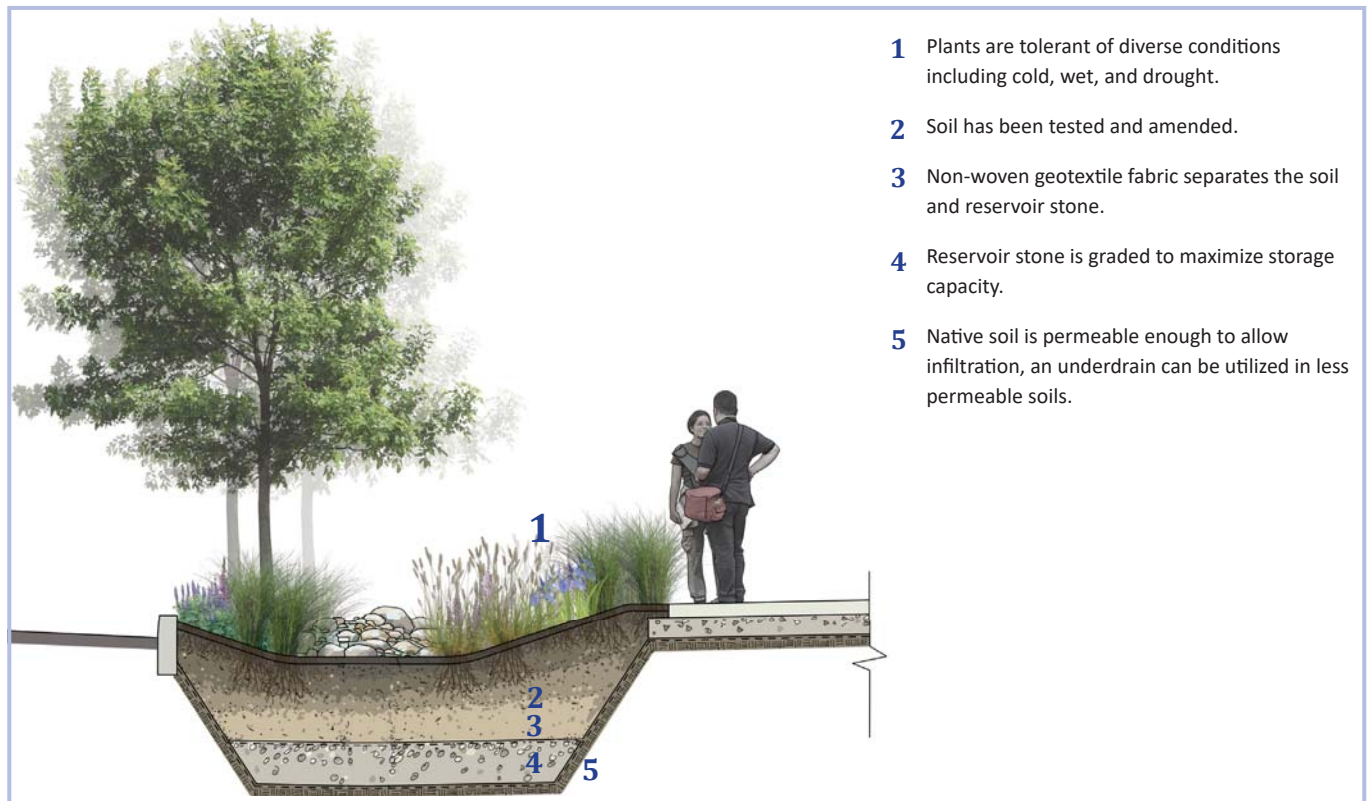

### **Surface Composition**

Concentrate permeable surfaces and pavements in areas to improve the quality of infiltration, bio-infiltration, and evapo-transpiration.

### **Pollutant Sources**

Minimize use of materials such as treated lumber, galvanized steel, zinc, copper, and synthetic sources of plant treatments and salt to reduce the source of pollutants and chemicals that could be carried through water flow over the site.

### **Typical Bump-out Rain Garden Section**



## ***Biodiverse Composition***

A selection of trees with an understory of shrubs and herbaceous materials should be provided. Vegetation should be selected based on a specified zone of hydric tolerance\*. Woody vegetation should not be located at inflow locations, or in snow storage areas.

Refer to the ***GI Retrofit Manual Section 3.1.3*** for more information.

## **E. EDUCATIONAL OPPORTUNITY**

Capitalize on educational and interpretive opportunities in all stormwater designs. This includes signage and/or panels that explain the hydrological system and provide viewers with unique experiences to understand the importance of conserving open space and vegetated landscape. This education will assist in promoting environmental awareness, appreciation, and stewardship.

### ***Training Maintenance Staff***

Providing information about the purpose of green infrastructure, how it functions, and how to care for it, can increase staff buy-in and improve the effectiveness of maintenance (***The Need for National Green Infrastructure Training and Certification***).

### ***Training Construction Staff***

Many of the techniques for installing green infrastructure are different than typical construction best practices, therefore certified staff or certifying municipal staff is one way to increase the impact of GI and potentially decrease long term costs, such as through ***The National Ready Mixed Concrete Association*** certification programs.

## **F. LANDSCAPE SCENARIOS**

Each site design should meet a certain set of criteria beyond these general guidelines. This varies in regards to appropriate green infrastructure practices, expected on-site drainage, and surface composition.

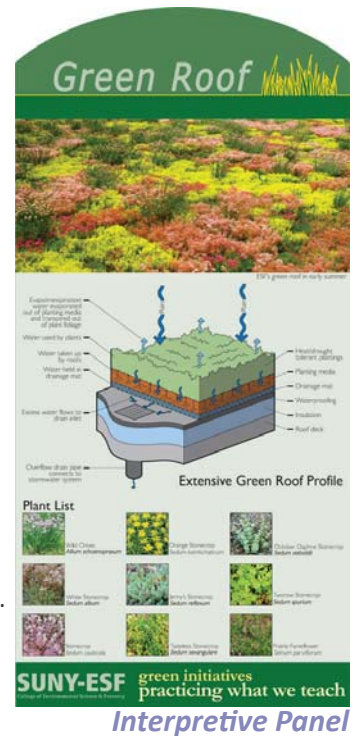

## LANDSCAPE GUIDELINES

# MATERIALS

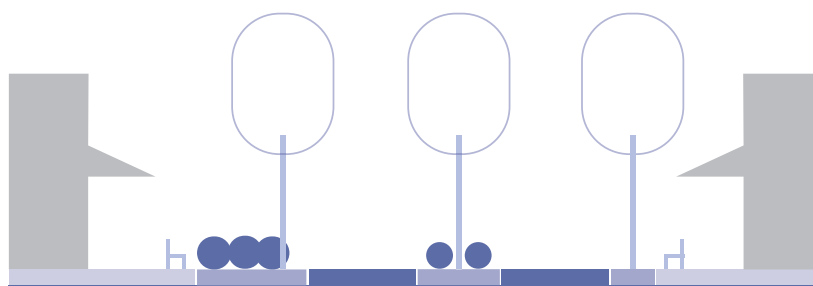

2.5

### A. OVERVIEW

Material selection affects the ability to reduce impacts of the urban heat island, improve stormwater management, provide safety and security to visitors, and increase property value. The suite of materials used in the final site design are significantly influenced by local availability, context, functionality, and aesthetic.

### B. PRE-DESIGN SITE ASSESSMENT

The **site analysis diagram** should document all materials, including those salvageable for re-use on site, and the corresponding area of coverage. If there are limited or no reusable material, search for local sources or consider other types.

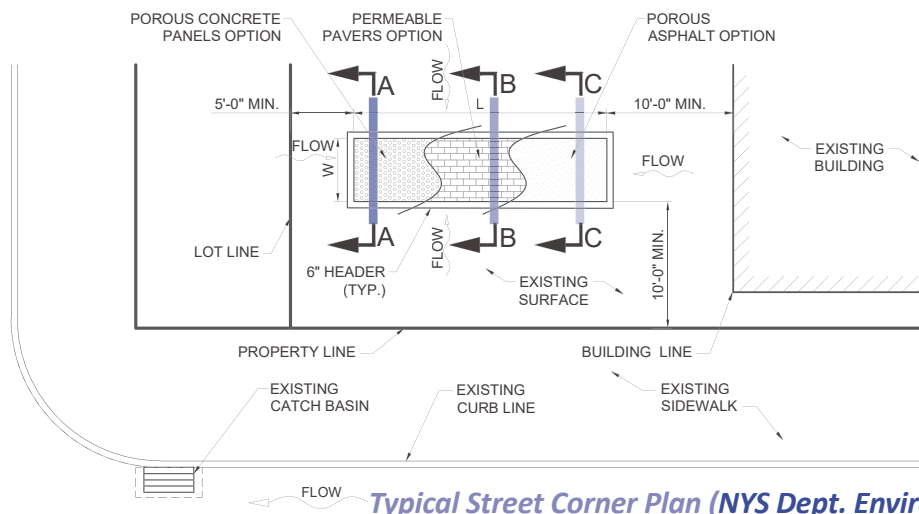



## C. MATERIAL SELECTION

Strive to use durable, sustainable, and intriguing materials that will persist in the landscape.

### C1. SOURCING

Prioritize materials available locally or harvested sustainably.

### C2. SURFACE COMPOSITION

Consider the ratio of impermeable to permeable material on site. The amount of permeable cover should mitigate the impacts of runoff and provide infiltration for storm events. Though calculations are necessary for each site, approximately 1/4 to 1/5 of impermeable surface to permeable surface should be used as a baseline ratio for a bio-retention area.

### C3. REUSE & RECYCLE

Re-use salvaged materials of high quality found on site to the maximum extent. These materials include use of existing site plantings, structures, building material, pavement, and amenities, whether that includes disassembly or preservation of each. Where possible, recover and recycle organic materials for soil and excavated boulders for landscaping. This can give a landscape a naturally occurring appearance if stone, wood, and crushed paving materials are used for infrastructure.

### C4. ALBEDO\*

Provide shade with vegetation and/or structures, especially over paved areas. Prioritize pavement and structural materials that lessen the absorption of UV rays. Materials that reflect a high amount of sunlight have a high albedo, and do not contribute as significantly to the urban heat island.

### C5. PERMEABLE MATERIAL

Use permeable concrete, permeable asphalt,

## QUICK REFERENCE GUIDE ✓

### Sourcing

- ✓ Source material primarily available locally or regionally.
- ✓ Ensure manufacturer's warranty is provided for products and systems including pavement, walls, structures, and waste receptacles.

### Surface Composition

- ✓ Comply with **SITES** by preserving 50% minimum of the total vegetated surface area on site, if deemed feasible.

### Permeable Material

- ✓ If under new construction, at least 50% of proposed pavement must be permeable if stormwater is not directed into another green infrastructure system.
- ✓ If under re-construction, at least 25% of re-developed pavement must be permeable (**GI Retrofit Manual**).

### Albedo

- ✓ Use materials with a three-aged solar reflectance value\* of at least .28 (**LEED v4**).

### Reuse & Recycle

- ✓ Reuse 20% of on-site, or off-site, material for proposed features, if determined feasible.
- ✓ Use sustainably harvested material for at least 15% of the specified materials on-site.

### Special Consideration: Prohibited materials

- ✓ Prohibit chemically treated wood, synthetic chemicals, dyed mulches, plastic and non-woven geo-textile, synthetic burlap, galvanized steel, raw manure, triple super-phosphate, muriatic acid, potash, modified seed, and sewage sludge.



permeable interlocking paving unit systems, and/or flexi-pave when applicable. Studies at the **University of New Hampshire Stormwater Center** show salt reduction up to 75% on porous pavements, while maintaining the equivalent amount of walkability. Reference **3.1.2 of the GI Retrofit Manual**, and **NYS Dept. of Environmental Protection** details below.

### Typical Permeable Pavement Details

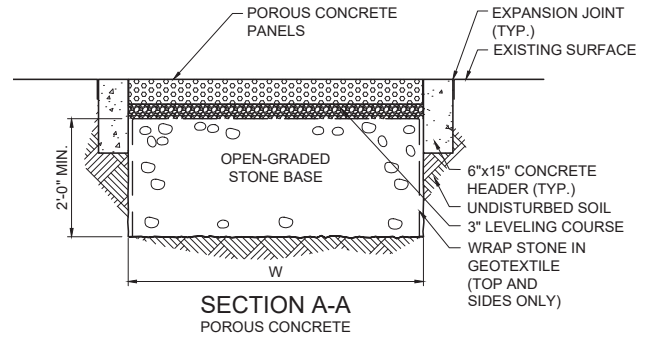

#### Porous Concrete

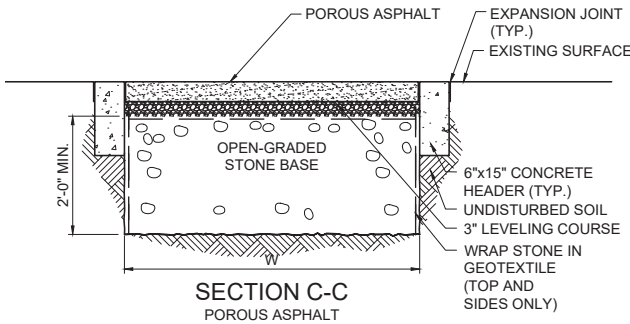

#### Porous Asphalt

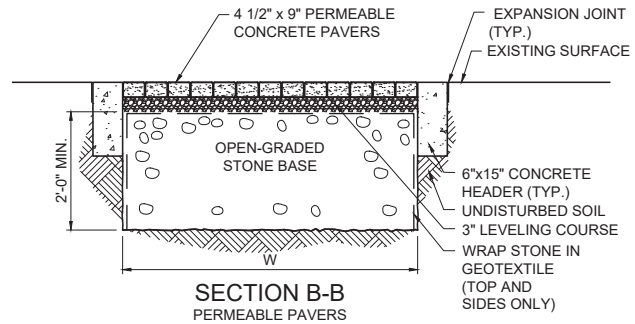

#### Porous Pavers

### Typical Rain Garden Detail

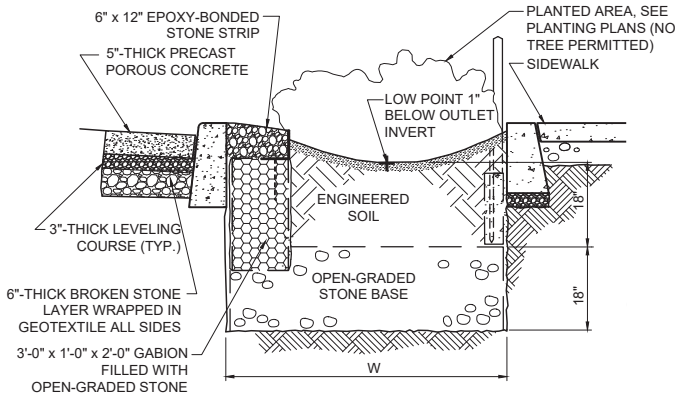

***"The area considered for runoff reduction is limited to the permeable area in which trees are planted. For up to a 16-foot diameter canopy of a mature tree, the area considered for reduction shall be 1/2 the area of the tree canopy. For larger trees, the area credited is 100 SF per tree."***

**-GI Retrofit Manual**

## D. EDUCATIONAL OPPORTUNITY

Capitalize on educational and interpretive opportunities to discuss the materials used on site, especially with historic significance, green infrastructure capability, or custom design. This education will assist in promoting environmental awareness, appreciation, and stewardship.

## E. LANDSCAPE SCENARIOS

Each site design should meet a certain set of criteria beyond these general guidelines. Material needs may differ in regards to permeability, durability, and availability.

LANDSCAPE GUIDELINES

# CONNECTIVITY, TRANSITIONS, & BUFFERS

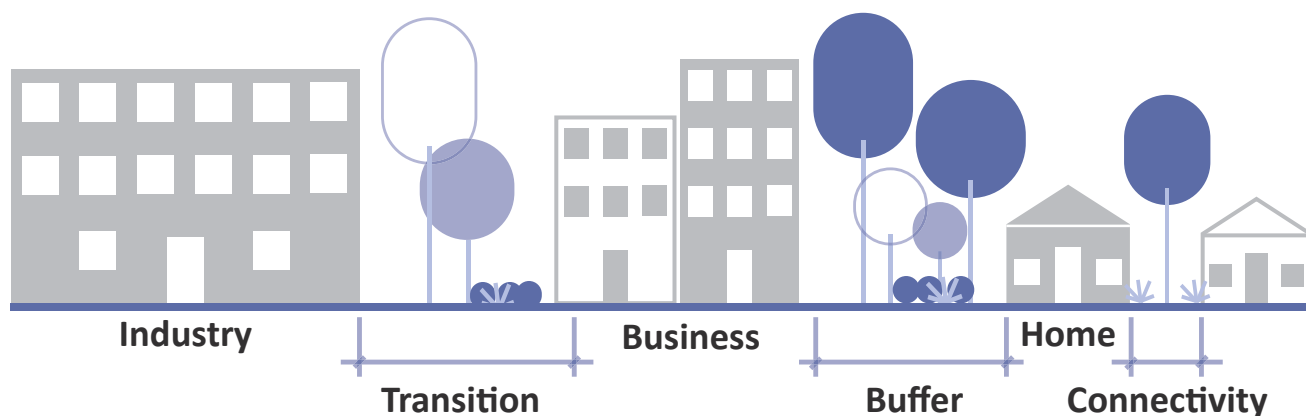

## A. OVERVIEW

§295-60 of the *Henrietta Town Code* provides guidance on the general characteristics of land use districts, as well as appropriate buffering space between properties. This guideline provides guidance on how to appropriately design these spaces with plant material to **connect**, **transition** between, or **separate** properties.

## B. PRE-DESIGN SITE ASSESSMENT

Evaluate the context of the site, including existing circulation, character, and land uses. Use the chart below to determine what considerations should be made along exterior edges of the site.

2.6

*Table 3.0 Degree of Separation*

CATEGORY	DEFINITION	COMPATIBILITY	CONCEPTS	LANDSCAPE
Connectivity	Connect site with adjacent properties	Compatible or same land uses	Physical: link properties with paths or openings Visual: expansive view; provide sightlines	High Transparency: Low plants (less than 3' high) and high canopy trees (more than 8' high); perennials, large trees; similar texture and color; uniform pattern
Transition	Shift from site to adjacent properties	Complementary land uses	Physical: shared space; create distinction Visual: blur the view	Some Density: Layer low, to medium, to high plant material; shrubs and medium trees; deciduous; somewhat clustered
Buffer	Barrier between site and adjacent properties	Incompatible land uses	Physical: separate with structure or materials Visual: block the view	High Density: High structural diversity; shrubs, medium trees, large trees; evergreen; clustered





## C. CONNECTIVITY

Means of physically and visually linking properties. Compatible land uses are those which are the same.

### C1. PLANT MATERIAL

Provide expansive views or sightlines towards a certain focal point by using low shrubs, and high canopy trees in a uniform pattern.

## D. TRANSITIONS

Shared zones between complementary land uses. One example is a multi-use property abutting a commercial property, providing a link from homes to jobs.

### D1. PLANTING GUIDANCE

Layer plants low to high height to create the illusion that the property is larger than it is.

## E. BUFFERS

Buffers provide a barrier between incompatible land uses. For example, an industrial property adjacent to a single family residential property.

### E1. SHIELDING

Expand [§205-9 of the Henrietta Town Code](#) guidance to include pump or gas stations, electrical facilities, and sensitive habitats.

### E2. PLANTING GUIDANCE

Mitigate noise, vibration, and particles from adjacent sites with structures, berms, or dense vegetation. Examples include heavy traffic, electric stations, trains, or dust and debris.

## F. LANDSCAPE SCENARIOS

Appropriate landscape approaches cannot be prescribed for all individual scenarios due to variations such as land use mixes, context, and relationship between property owners. However, landscape approaches at every site should consistently address safety, sustainability, and four season visual interest.

## QUICK REFERENCE GUIDE ✓

### Connectivity

- ✓ Establish clear pedestrian routes and sightlines between spaces intended for users.
- ✓ Connect and enrich ecological communities within or bordering the site by incorporating consistent plant species and groupings ([SITES](#)).

### Transitions

- ✓ Layer plantings low to high using deciduous shrubs and medium trees in a cluster to define transition zone along lot line.
- ✓ Greenbelts between adjacent land uses that abut single-family residential must be at least 50' in width.

### Buffers

- ✓ Densify plantings with high structural diversity and evergreen species in a cluster to block or screen the view between properties.
- ✓ Provide plantings that are at least 2.5' in height to buffer the edge of parking lots.

### Shielding

- ✓ Shield pump stations, gas stations, and electrical facilities from public view. Block access from at least 50' proximity in compliance with [Henrietta Town Code §205-9](#).
- ✓ Prohibit development less than 20' from non-regulated ecologically sensitive areas. Restrict access to reduce potential interactions ([SITES](#)).



## LANDSCAPE GUIDELINES

# MAINTENANCE



### A. OVERVIEW

Maintenance is key to the persistence of functional landscapes. Therefore, maintenance planning must be carefully crafted to adequately attend to the upkeep of all site features. While some site designs may require higher amounts of attention, the availability and ability of the maintenance group is variable.

To ensure thoroughness and feasibility, consider revising the Town Code to have maintenance schedules reviewed and approved by the Engineering Department and recorded in the office of the County Clerk as a deed restriction on the property prior to the final site design approval.

See [§236-32 and §261-5 of the Henrietta Town Code](#) for more information.

2.7

### B. INVENTORY AND ANALYSIS

Understand the capabilities of staffing and equipment. Then, assess the maintenance needs and activities for the proposed site. Activities may include assessing and fixing erosion issues, pruning trees, removing debris, and/or replacing or reseeding plantings. Compare existing versus proposed conditions, then analyze the feasibility of upkeep. Understanding these possibilities is imperative to the resiliency of each site design.

#### B1. EQUIPMENT

Inventory what tools and equipment the maintenance staff can already access versus what they will potentially need to meet scheduled maintenance activities.





## C. MINIMIZE COMPLICATION

Maximize the potential survivability and persistence of the proposed landscape by selecting materials with low maintenance requirements, creating a feasible maintenance schedule, and planning for changing conditions.

### C1. LOW-MAINTENANCE SPECIES

Investigate the level of potential upkeep, including pruning and irrigation of each selected species. Prioritize low maintenance, disease resistant, and native species.

### C2. LANDSCAPE DYNAMICS

Consider continual assessment and performance monitoring. Landscapes are dynamic systems that do change over time with changing conditions and maturity.

## D. MAINTENANCE AGREEMENT

Complete a maintenance agreement with the Town, coordinating with the Engineering Department.

### D1. COORDINATION

Formalize a plan for maintenance access, continual education, and coordination for larger scale projects. An administrative staff may be needed to coordinate these activities, issue work orders, supervise, monitor performance, and track progress. The administrative staff may also occasionally supervise maintenance staff to confirm that the prescribed activities are being performed correctly and at an appropriate frequency.

### D2. LETTER OF CREDIT

Currently, the Town of Henrietta's requirements state, "Upon completion and acceptance of the landscaping, a two-year maintenance agreement will be required of the Town of Henrietta. The maintenance guarantee will be for two years from the date

## QUICK REFERENCE GUIDE ✓

### **Landscape Guarantee**

- ✓ Sign three year contract in agreement with the **Chapter 236-32 and 261-5** of the **Henrietta Town Code, Landscape Guarantee**.

### **Maintenance Schedule**

- ✓ Provide a feasible 10-year maintenance schedule with proposed activities.

### **Documentation**

- ✓ Retain record of installation, operation, and ongoing maintenance ten years post activity (**LEED v4**).

### **Damages and Repairs**

- ✓ Within one month of observation of damaged infrastructure, replacements must be implemented within 60 days (**Town Code**).
- ✓ Within one month of observation of damaged or dead plant material, reactive measures or replacements must be implemented within 30 days.

### **Inspection**

- ✓ Schedule inspection five years after construction closeout (**Town Code**).

### **Performance Monitoring**

- ✓ Partner with a local organization to monitor performance of stormwater infrastructure.



of final acceptance of each section of the subdivision” (*§261-11 of the Henrietta Town Code*). However, this period is not long enough to ensure upkeep and establishment of plantings and stormwater management infrastructure.

**These guidelines recommend this contract now be upheld for three years after project closeout.**

This change accounts for the appropriate period of establishment that occurs over the course of two to three major seasonal changes, over which plantings will either thrive or fail. Although this may challenge the capacity of the Town to uphold, there are potential partner opportunities available with local organizations, universities, and internships.

### D3. MAINTENANCE SCHEDULE

Refer to *§236-32 and §261-5*, as well as *§A301 Fee Schedules of the Henrietta Town Code* for inspection costs and schedule. See *Appendix E* for a full list of maintenance activities. For approved site designs, inspection will occur five years after construction closeout. See *Appendix F* for more inspection forms. While a 5 year plan is all that is necessary for maintenance, best practice is to anticipate activities required for a 10-year management plan (*LEED v4*).

Consider the following factors when determining scheduling frequency:

- GI practice type (i.e., bio-retention, porous pavement, rain barrel, etc.),
- Site specific factors (dependent on actual site conditions such as runoff volume, traffic loading, sediment loading, litter/debris loading, etc.),
- Seasonal variations (i.e., fall leaf drop, snow removal, etc.),
- Temporary adjacent site activities (i.e., construction), and
- Irregular weather events” (A Survey of Green Infrastructure Maintenance Programs).

See the *GI Retrofit Manual Section 5.1* for reference.

MAINTENANCE	SUGGESTED SCHEDULE
Add additional mulch.	Annually.
Remove sediment, litter, and other buildup from catch basins, inlets, and drainage pipes.	Twice Annually.
Prune vegetation.	Annually.
Water plan.	Seasonally.
Inspect and evaluate tree and vegetation health.	Twice annually.
Remove, replace or reseed plantings.	Annually.

*Example Activities to Include in the Maintenance Schedule.*

### E. ON-GOING OPERATIONS

Continually observe and maintain the site once plantings have established. Oversee the need for removal and replacement of plant material that do not survive over time.



## E1. DOCUMENTATION

Record installation, operation, and ongoing maintenance **for at least ten years post-activity to ensure post-inspection maintenance plans are continually being met.** Construction activities already approved may be amended of this requirement.

### *Documentation Strategies*

Use paper checklists, spreadsheets and databases, Asset Management Systems, Geographic information systems (GIS), and Computerized Maintenance and Management Systems (CMMS) to document on-going maintenance and construction activities (*GI Retrofit Manual*).

## E2. DAMAGES AND REPAIRS

Negotiate expectations for repairing landscape features with Town officials, especially in consideration of timing around the winter season or the potential for emergency situations. Replacement of plant material must be of comparable species and size, as well as pre-approved by the Town.

## E3. INFILL PLANTING

Three to five years after construction, when plants are established, determine if there is a need for a second infill planting\* (*GI Retrofit Manual*). Avoid performing these activities during the winter season.

## F. PERFORMANCE MONITORING

“Monitoring is not necessary for all projects. However, Monroe County boasts exceptional educational institutions which are leaders in technical innovation. Where appropriate, working with universities and citizen science organizations... can be very beneficial” (*GI Retrofit Manual Section 5.10*).

Consider the following factors when determining if monitoring is appropriate for the site:

- Location of monitoring,
- Monitoring method,
- Monitoring frequency,
- Necessary equipment/supplies,
- Cost, and
- Priority.

Besides educational opportunities with signage and/or interpretive panels, these monitoring mechanisms add another level of community engagement, offering potential involvement with local organizations, universities, or internship programs. These investigations also help determine which practices are the most beneficial in Henrietta, and will raise awareness for the Town’s effort to improve its standards for site design in regards to the landscape.

## G. FUNDING

Funding maintenance practices is necessary for all projects to persist in the landscape. Due to limitations in conventional funding sources, such as the NYS Tax Cap, municipalities may benefit from considering alternative means of funding GI projects. See the *GI Retrofit Manual Section 2.5* for more information.



## 3.0 LANDSCAPE SCENARIOS



### A. SITE GUIDE

While the guidelines break down the requirements of site design, this chapter provides a guide that breaks down the vision and expectations of site design in the Town of Henrietta. Each landscape typology description provides conceptual goals and recommendations that should inform decisions throughout the site design and site review process.

### B. LANDSCAPE SCENARIOS

There are three main landscape scenarios that offer opportunities to enhance landscape functionality.

- 1. Surface Parking**
- 2. Office and/or Multi-Use Complexes**
- 3. Streetscape**



### C. SURFACE PARKING

Planting within surface parking requires coordination between utilities, circulation, emergency vehicle access, lighting, and pedestrian access. Study the current patterns of circulation, surrounding site context, stormwater management, and activity of the business or anticipated activity to understand the gaps between existing conditions and proposed conditions.

#### DESIGN GOALS

It is important to consider strategies to integrate vegetation into parking lots to improve their function and attractiveness. While **§295-17 of the Henrietta Town Code** indicates the owner plant ground cover and street trees, these guidelines require consistent amounts of vegetation throughout landscaped malls and parking lots.

#### ***Circulation***

Accommodate all modes of transportation into parking lot design. One bio-infiltration island is required per parking row, located at the ends of all parking rows, sides of ingress/egress aisles, and pedestrian access pathways. These islands should define circulation within the parking lot and provide space for snow removal. Accommodate pedestrian and bicycle mobility between building entrances and the public right of way, especially in commercial districts.

#### ***Materials***

Understand and accommodate for the proposed parking capacity. Breaking up the “sea of asphalt” will increase the property value of the lot and improve the visual quality of the business.

#### ***Vegetation***

Layer plantings to enhance pedestrian and vehicular comfort. Plantings should preserve sightlines from arrival to destination, buffer and transition to surrounding lots, and reduce urban heat island effects. Maintain continuous vertical height of plantings to 2.5’-3.5’ consistently around parking lot and set at least 2’ back from curbing. Ensure plantings establish to provide a visual distinction and barrier. As a new minimum requirement, provide one tree per every 10 parking spaces to provide adequate cooling through interspersed shade throughout the parking lot.

#### ***Accessibility***

Ensure there is adequate pedestrian service and wayfinding. If there are gaps in adequate levels of service and facilities, provide opportunities to re-design the site with universal accessibility features that enhance the existing site character or develop a new character.

#### ***Stormwater Management***

Integrate vegetation that will adapt to changing conditions, drainage patterns, and infiltration rates on site. Species should be flood and drought tolerant if used for bio-retention or bio-infiltration, with some level of salt tolerance for salting during winter time conditions. Drainage basins must be in accordance with drainage patterns and include drop curbs at end of swales. These basins must reach a minimum width of 5’ to provide adequate space for basic tree rooting. Continuous tree trenches are recommended within the area to maximize potential rooting volume.



### D. OFFICE AND/OR MULTI-USE COMPLEXES

Office and/or Multi-Use Complex landscape design involves careful arrangement and understanding of use that will significantly impact the daily life of staff or residents in that place, whether it be a small gathering space or a remote place that people will look at passing by or from their windows.

#### **DESIGN GOALS**

These sites are often temporary or transitional places. Providing four season, colorful vegetation, and understanding circulation and use are the most important considerations.

#### ***Circulation***

Understand what places are most appropriate and convenient for people to gather both during and after work hours if residential development is on site. Ensure there are paths and sightlines from buildings and roads to outdoor spaces that provide unique experiences and enhance the character of the residing business and homes.

#### ***Vegetation***

Provide distinct sightlines from office windows by layering plantings, textures, and color within the four season visual quality to create a diverse experience year-round. Do not plant vegetation with a mature height above a building window near the building, nor plant woody shrubs within 2' of building. Do not plant trees within 10' of building. Use medium sized vegetation to frame the view from lower floors and canopy trees to frame the view from upper floors. Incorporate distinctive plantings at entrances.

#### ***Accessibility***

Ensure there is adequate pedestrian service and wayfinding. This means drop curbs and ramps, rumble strips, appropriate pavement details, and space for flow.

#### ***Materials***

Incorporate a mix of materials that reflect the character of the complex, and appropriately proportion the mix of impermeable to permeable cover to create a dynamic and diverse landscape to view.

#### ***Stormwater***

Stormwater management should be a focus of design in these settings since there are often many buildings. Incorporate rain gardens and permeable pavement paths towards the building that capture roof and driveway runoff. Designate retention areas to avoid flooding along pathways, especially to and from buildings.



### E. STREETSCAPES

Streetscape design often involves limitations due to pre-existing conditions, defined by a constrained size and circulation. With confined and limited space, unideal growing conditions, and utilities, street planting design must be strategic to not damage or impair streetscape infrastructure.

Refer to the *Town of Henrietta Design Guidelines for Multiple Family Dwellings* for more information.

#### DESIGN GOALS

The presence of landscaping along the streetscape is significantly impacted by thoughtful approaches to site design. It is important to use strategies that integrate a vibrant street corridor with a system of coordinated safety, coordination between users, circulation, scale, and function.

##### ***Circulation***

Accommodate all modes of transportation in a safe manner including pedestrians, bicyclists, motorists, and public transit. Utilize bump-outs, high visibility crosswalks, curbing, vegetation, or visual cues, as well as scale of height and width for traffic calming.

##### ***Scale***

Maintain consistency along the street by planting one tree per approximately every 30-40 linear feet if spread is more than 20', and every 20-30 linear feet if spread is less than 20', of right-of-way or lot frontage. This may vary due to utility locations and proximity of prominent architecture. It is recommended that trees with a mature canopy of under 25' should be used where overhead utilities are present. See ***Setbacks*** in ***Section 2.3*** for more information.

##### ***Vegetation***

Trees should be installed in areas with a width of at least 5' from curb to sidewalk. This will minimize snow plow obstructions, especially if planted away from the pavement edge, and provide adequate rooting volume. Trees must be placed at least 8' from the edge of driveways, with projection over sidewalks, paths, or trails prohibited below 8' height. Canopy may extend over roadway, but trunk may not lean over roadway. When expecting truck traffic, clearance must be at least 16' in height. Evergreen trees are prohibited in the streetscape within the right of way if obstructing views and creating potentially hazardous situations.

##### ***Accessibility***

Ensure there is adequate pedestrian service and wayfinding through drop curbs and ramps, rumble strips, appropriate pavement details, and space for flow.

##### ***Stormwater Management***

Bio-infiltration areas should be designated to channel and infiltrate roadway runoff in regular intervals before being directly piped into stormwater infrastructure. These areas should be distinctly defined, and if over a 1.5' depth, should have a barrier or railing surrounding the area.



## APPENDIX A

# QUICK REFERENCE GUIDE

## 2.1 PUBLIC HEALTH & WELL-BEING 10

---

- Use 8' in height or higher canopy trees, and 3' in height or lower plants along sidewalks and walkways.

## 2.2 SOILS 12

---

- Use a minimum of 6" topsoil, 8" preferred.
- Seed and mulch stockpiles if they will not be moved within 1 week for slopes 3:1 or steeper, and 2 weeks for slopes 3:1 or flatter.
- If not engineered slopes, prohibit berms, cut, and fill slopes steeper than 2:1 maximum; 3:1 preferred. These must not be higher than 3'.
- Re-vegetate, establish, and attend to plant materials within 6 months of initial disturbance.

## 2.3 VEGETATION & PLANTINGS 15

---

- Use 50% native species in final plant list.
- Select native species classified as Region 5b, 6a, or 6b for heat tolerance, and 2, 3, or 4 for cold tolerance, within the **Plant Hardiness Zone** guidance.
- Plant no more than 10% of any species, no more than 20% of any genus, and no more than 30% of any family as recommended by **SITES**.
- Use 1.5"-2.0" caliper bare root trees.
- Locate small trees at least 10'-15' from building foundations.
- Provide as appropriate and as determined by the Town of Henrietta:
  - o 1 tree per every 10 parking spaces
  - o 8 trees per acre, as required by the Conservation Board
  - o 2 trees per every 1 tree removed on site
- Space plant material, at minimum, as follows:
  - o Large trees: 35' on center
  - o Medium trees: 20' on center
  - o Small trees: 20' on center
- Locate understory plant material at least 2' from tree trunks as recommended by **SITES**.
- Provide root volume, at minimum, as follows:
  - o Large to medium trees: 500 CF
  - o Medium to small trees: 300 CF
- Appropriately mulch plant material according to the following:
  - o Avoid mulching past root flare
  - o Expose root flare 1"-2" above ground level
  - o Use 3"-4" of mulch around woody plants
  - o Use 1"-2" of mulch around herbaceous plants





---

## 2.4 STORMWATER MANAGEMENT

22

- Exceed capacity for on-site infiltration by at least 20-25% minimum; 30% preferred.
- Ensure standing water is infiltration in less than 3 days to avoid mosquito breeding.
- Design for the 24 hour anticipated peak flow 100-year storm conditions using data from the *Extreme Precipitation in New York & New England* interactive web tool as recommended by the *NYS Department of Environmental Conservation*.
- Locate bio-retention at least 10' from building foundations; if not possible, use an impermeable liner to protect foundation.

---

## 2.5 MATERIALS

27

- Preserve a minimum of 50% of the total vegetated area on site as recommended by *SITES*.
- If under new construction, out of the total proposed pavement, install 50% permeable if stormwater is not directed into another green infrastructure system (runoff is directly entering stormwater piping).
- If under re-construction, out of the total proposed pavement, install 25% permeable, as recommended by the *City of Rochester & Monroe County Green Infrastructure Manual*.
- Use materials with a 3-aged solar reflectance value of at least 0.28 as recommended by *LEED v4*.
- Aim to supply 20% of the total materials with re-used materials. Re-used materials off-site adequate; on-site preferred.
- Use sustainably harvested material for at least 15% of the specified materials on-site.

---

## 2.6 CONNECTIVITY, TRANSITIONS, AND BUFFERS

30

- Prohibit development less than 20' from non-regulated ecologically sensitive areas. Restrict access to reduce potential interactions as recommended by *SITES*.
- Shield pump stations, gas stations, and electrical facilities from public view. Block access from at least 50' proximity in compliance with the *Town of Henrietta Code*.
- Provide plant material at least 2.5' in height around parking lots.

---

## 2.7 MAINTENANCE

32

- Maintain a 3-year contract for the Landscape Guarantee.
- Retain record of installation, operation, and on-going maintenance 10-years post activity as recommended by *SITES*.
- Within 1 month of observation of damaged infrastructure, replacements must be implemented within 60 days in accordance with the *Town of Henrietta Code*.
- Within 1 month of observation of damaged or dead plant material, reactive measures or replacements must be implemented within 30 days.
- Schedule inspection 3-5 years after construction closeout.



APPENDIX B

# NYS NATIVE PLANTS

## LADYBIRD JOHNSON WILDFLOWER CENTER

## New York Recommended

Commercially available native plant species suitable for planned landscapes in New York. Visit our [Suppliers Directory](#) to locate businesses that sell native plants or seeds or provide professional landscape or consulting services in this state. Visit the [Organizations Directory](#) to locate native plant societies, conservation groups, governmental agencies, botanical gardens, arboreta, and other plant-related organizations in this state.

Scientific Name	Common Name	Duration	Habit	Sun	Water
<i>Acer rubrum</i>	Red Maple, Scarlet Maple, Soft Maple	Perennial	Tree	Sun, Part-shade	Moist
<i>Acer saccharinum</i>	Silver Maple, Soft Maple, White Maple	Perennial	Tree	Sun, Shade, Part-shade	Moist
<i>Acer saccharum</i>	Sugar Maple, Northern Sugar Maple	Perennial	Tree	Sun, Shade, Part-shade	Moist, Dry
<i>Achillea millefolium</i>	Common Yarrow, Western Yarrow, Yarrow, Milfoil	Perennial	Herb	Sun, Part-shade	Dry
<i>Actaea pachypoda</i>	White Baneberry, Dolls Eyes	Perennial	Herb	Shade, Part-shade	Wet, Moist
<i>Actaea rubra</i>	Red Baneberry	Perennial	Herb	Sun, Shade, Part-shade	Moist
<i>Adiantum pedatum</i>	Northern Maidenhair Fern, Maidenhair Fern	Perennial	Fern	Shade, Part-shade	Moist
<i>Amelanchier canadensis</i>	Canadian Serviceberry, Canadian Service-berry, Shadblow Serviceberry, Juneberry, Shadbush, Junebush	Perennial	Tree	Sun, Shade, Part-shade	Wet, Moist
<i>Anaphalis margaritacea</i>	Western Pearly Everlasting, Pearly-everlasting	Perennial	Herb	Sun, Part-shade	Dry
<i>Anemone canadensis</i>	Canadian Anemone, Round-leaf Thimbleweed, Canada Anemone, Windflower, Meadow Anemone	Perennial	Herb	Shade, Part-shade	Moist
<i>Aquilegia canadensis</i>	Eastern Red Columbine, Wild Red Columbine	Perennial	Herb	Shade, Part-shade	Moist, Dry
<i>Asclepias tuberosa</i>		Perennial	Herb	Sun	Moist, Dry

	Butterflyweed, Butterfly Milkweed, Orange Milkweed, Pleurisy Root, Chigger Flower				
<i>Asimina triloba</i>	Pawpaw, Common Pawpaw, Custard Apple, Indian Banana, Wild Banana	Perennial	Tree	Sun, Shade, Part- shade	Moist
<i>Betula lenta</i>	Sweet Birch, Cherry Birch, Black Birch, Mahogany Birch	Perennial	Tree	Shade, Part- shade	Moist, Dry
<i>Betula populifolia</i>	Gray Birch, White Birch, Aspen-leaved Birch	Perennial	Tree	Sun, Shade, Part- shade	Wet, Moist, Dry
<i>Campanula rotundifolia</i>	Bluebell Bellflower, Bluebell Of Scotland, Bluebell, Harebell, Witches' Thimble	Perennial	Herb	Sun, Shade, Part- shade	Dry
<i>Campanulastrum americanum</i>	American Bellflower, Tall Bellflower	Annual	Herb	Part- shade	Moist
<i>Campsis radicans</i>	Trumpet Creeper, Trumpet Vine, Common Trumpet Creeper, Cow Vine, Foxglove Vine, Hellvine, Devil's Shoestring	Perennial	Vine	Sun	Moist, Dry
<i>Carpinus caroliniana</i>	American Hornbeam, Blue Beech, Water Beech, Musclewood, Ironwood	Perennial	Tree	Shade, Part- shade	Moist
<i>Carya glabra</i>	Pignut Hickory, Sweet Pignut Hickory, Coast Pignut Hickory, Pignut, Sweet Pignut, Smoothbark Hickory, Broom Hickory, Red Hickory, Swamp Hickory, Switch Hickory, Switchbud Hickory	Perennial	Tree	Sun, Shade, Part- shade	Dry
<i>Carya ovata</i>	Shagbark Hickory, Carolina Hickory, Scalybark Hickory, Upland Hickory, Shellbark Hickory	Perennial	Tree	Sun, Shade, Part- shade	Moist, Dry
<i>Carya tomentosa</i>	Mockernut Hickory, Mockernut Hickory, Big Bud Hickory, Mockernut, White Hickory, Whiteheart Hickory, Fragrant Hickory, Bigbud Hickory, Hardbark Hickory, Hognut, Bullnut	Perennial	Tree	Part- shade	Moist
<i>Ceanothus americanus</i>	New Jersey Tea, Redroot	Perennial	Shrub	Shade, Part- shade	Moist, Dry
<i>Cercis canadensis</i>	Eastern Redbud, Redbud	Perennial	Tree	Shade, Part- shade	Moist
<i>Chamaecyparis thyoides</i>	Atlantic White Cedar	Perennial	Tree	Part- shade	Wet
		Perennial	Herb	Sun	Moist

<i>Chamerion angustifolium</i> ssp. <i>angustifolium</i>	Fireweed, Narrow-leaf Fireweed, Willow Herb				
<i>Claytonia caroliniana</i>	Carolina Springbeauty	Perennial	Herb	Part-shade	Wet, Moist
<i>Claytonia virginica</i>	Virginia Springbeauty, Springbeauty	Perennial	Herb	Part-shade	Moist
<i>Conoclinium coelestinum</i>	Blue Mistflower, Wild Ageratum, Blue Boneset	Perennial	Herb	Sun, Part-shade	Moist
<i>Coreopsis lanceolata</i>	Lanceleaf Coreopsis, Lance-leaved Coreopsis, Lanceleaf Tickseed, Sand Coreopsis	Perennial	Herb	Sun, Shade, Part-shade	Dry
<i>Cornus alternifolia</i>	Alternateleaf Dogwood, Alternate-leaf Dogwood, Pagoda Dogwood	Perennial	Shrub	Shade, Part-shade	Moist
<i>Cornus florida</i>	Flowering Dogwood, Virginia Dogwood, Florida Dogwood, White Cornel, Arrowwood, American Boxwood, False Box, St. Peter's Crown, Corona De San Pedro	Perennial	Tree	Shade, Part-shade	Moist, Dry
<i>Desmodium canadense</i>	Showy Tick Trefoil	Perennial	Herb	Sun	Moist, Dry
<i>Eutrochium purpureum</i>	Purple Joepyeweed, Sweet-scented Joepyeweed, Sweet Joepyeweed	Perennial	Herb	Sun, Shade, Part-shade	Moist
<i>Fagus grandifolia</i>	American Beech, White Beech, Red Beech, Ridge Beech, Beechnut Tree	Perennial	Tree	Shade, Part-shade	Moist
<i>Fothergilla gardenii</i>	Dwarf Witchalder, Dwarf Witch-alder, Dwarf Fothergilla	Perennial	Shrub	Sun, Part-shade	
<i>Fraxinus americana</i>	White Ash, American Ash, Cane Ash, Smallseed White Ash, Biltmore White Ash, Biltmore Ash	Perennial	Tree	Sun, Shade, Part-shade	Moist, Dry
<i>Fraxinus nigra</i>	Black Ash	Perennial	Tree	Sun, Shade, Part-shade	Wet, Moist
<i>Gaultheria procumbens</i>	Eastern Teaberry, Wintergreen, Checkerberry	Perennial	Shrub	Shade, Part-shade	Moist, Dry
<i>Gaylussacia baccata</i>	Black Huckleberry	Perennial	Shrub	Sun, Shade, Part-shade	Wet, Moist, Dry

<i>Gaylussacia brachycera</i>	Box Huckleberry	Perennial	Shrub	Part-shade	
<i>Helianthus tuberosus</i>	Jerusalem Artichoke, Sunchoke	Perennial	Herb	Sun	Moist, Dry
<i>Hibiscus moscheutos</i>	Crimson-eyed Rose-mallow, Marshmallow Hibiscus	Perennial	Shrub	Sun, Part-shade	Wet, Moist
<i>Hypericum prolificum</i>	Shrubby St. John's-wort	Perennial	Shrub	Shade, Part-shade	Moist, Dry
<i>Ilex opaca</i>	American Holly, White Holly, Prickly Holly, Evergreen Holly, Christmas Holly, Yule Holly	Perennial	Tree	Sun, Shade, Part-shade	Wet, Dry
<i>Juglans nigra</i>	Black Walnut, Eastern Black Walnut, American Black Walnut	Perennial	Tree	Sun, Part-shade	Moist
<i>Juniperus virginiana</i>	Eastern Red Cedar, Eastern Redcedar, Virginia Juniper, Red Juniper, Pencil Cedar, Carolina Cedar, Red Savin, Baton Rouge	Perennial	Tree	Sun, Shade, Part-shade	Dry
<i>Kalmia latifolia</i>	Mountain Laurel, Calico Bush, Kalmia	Perennial	Shrub	Part-shade	Moist
<i>Larix laricina</i>	Tamarack, American Larch, Hacmatack, Black Larch	Perennial	Tree	Sun, Shade	Wet, Moist
<i>Liatris spicata</i>	Dense Blazing Star, Dense Gayfeather, Dense Liatris, Marsh Blazing Star, Marsh Gayfeather, Marsh Liatris	Perennial	Herb	Sun	Moist
<i>Liquidambar styraciflua</i>	Sweetgum, American Sweetgum, Red Gum, White Gum, Star-leaved Gum, Starleaf Gum, Alligator Tree, Satin Walnut, Bilsted, Liquidambar	Perennial	Tree	Part-shade	Moist
<i>Liriodendron tulipifera</i>	Tulip Tree, Tulip Poplar, Yellow Poplar	Perennial	Tree	Sun, Shade, Part-shade	Moist
<i>Lobelia cardinalis</i>	Cardinal Flower	Perennial	Herb	Sun, Shade, Part-shade	Wet, Moist
<i>Lobelia siphilitica</i>	Great Blue Lobelia	Perennial	Herb	Sun, Shade, Part-shade	Wet, Moist
<i>Lupinus perennis</i>	Sundial Lupine, Wild Lupine	Perennial	Herb	Sun, Part-shade	Moist, Dry
		Perennial	Herb		Moist

<i>Maianthemum racemosum</i> ssp. <i>racemosum</i>	Feathery False Lily Of The Valley, False Spikenard, False Solomon's Seal, Solomon's Plume, Smilacina			Shade, Part-shade	
<i>Maianthemum stellatum</i>	Starry False Lily Of The Valley, Starry False Solomon's Seal, Star-flowered Solomon's Seal	Perennial	Herb	Shade, Part-shade	Moist, Dry
<i>Malus coronaria</i>	Sweet Crabapple, American Crab	Perennial	Tree	Part-shade	Moist
<i>Matteuccia struthiopteris</i>	Ostrich Fern	Perennial	Herb, Fern	Shade, Part-shade	Moist
<i>Mitchella repens</i>	Partridgeberry, Twinberry, Running Box, Pigeon Plum	Perennial	Herb	Shade, Part-shade	Moist, Dry
<i>Mitella diphylla</i>	Twoleaf Miterwort, Miterwort	Perennial	Herb	Shade	Moist
<i>Monarda didyma</i>	Scarlet Beebalm, Oswego Tea, Red Bergamot	Perennial	Herb	Sun, Part-shade	Wet, Moist
<i>Monarda fistulosa</i>	Wild Bergamot, Beebalm	Perennial	Herb	Sun, Part-shade	Moist, Dry
<i>Nyssa sylvatica</i>	Blackgum, Black Tupelo, Tupelo, Sourgum, Pepperidge, Tupelo Gum	Perennial	Tree	Sun, Shade, Part-shade	Moist
<i>Osmunda cinnamomea</i>	Cinnamon Fern	Perennial	Herb, Fern	Sun, Shade, Part-shade	Wet, Moist
<i>Osmunda claytoniana</i>	Interrupted Fern	Perennial	Herb, Fern	Shade	Moist
<i>Osmunda regalis</i>	Royal Fern	Perennial	Herb, Fern	Shade, Part-shade	Wet, Moist
<i>Parthenocissus quinquefolia</i>	Virginia Creeper	Perennial	Vine	Sun, Shade, Part-shade	Moist
<i>Penstemon digitalis</i>	Mississippi Penstemon, Mississippi Beardtongue, Smooth White Penstemon, Smooth White Beardtongue, Talus Slope Penstemon, Talus Slope Beardtongue, Foxglove Penstemon, Foxglove Beardtongue	Perennial	Herb	Sun, Part-shade	Wet, Moist, Dry
<i>Penstemon hirsutus</i>	Hairy Penstemon, Hairy Beardtongue	Perennial	Herb	Sun, Shade, Part-shade	Dry
<i>Phlox divaricata</i>		Perennial	Herb		Moist



	Wild Blue Phlox, Louisiana Phlox, Blue Woodland Phlox, Sweet William, Wild Sweet William			Shade, Part-shade	
<i>Phlox subulata</i>	Creeping Phlox, Moss Phlox, Moss Pink, Rock Pink	Perennial	Herb	Sun, Part-shade	Dry
<i>Physostegia virginiana</i>	Fall Obedient Plant, False Dragonhead, Virginia Lions-heart	Perennial	Herb	Sun, Shade, Part-shade	Moist
<i>Picea rubens</i>	Red Spruce, Yellow Spruce, West Virginia Spruce, Eastern Spruce, He-balsam	Perennial	Tree	Sun, Shade	Moist, Dry
<i>Pinus resinosa</i>	Red Pine, Norway Pine, Canadian Pine	Perennial	Tree	Sun	Moist, Dry
<i>Pinus strobus</i>	Eastern White Pine, Weymouth Pine	Perennial	Tree	Sun, Shade, Part-shade	Moist, Dry
<i>Pinus virginiana</i>	Virginia Pine, Jersey Pine, Scrub Pine	Perennial	Tree	Sun	Moist
<i>Podophyllum peltatum</i>	Mayapple, Indian Apple, Wild Mandrake, Pomme De Mai, Podophylle Pelt	Perennial	Herb	Shade, Part-shade	Moist
<i>Polemonium reptans</i>	Greek Valerian, Jacob's Ladder	Perennial	Herb	Shade	Moist
<i>Polystichum acrostichoides</i>	Christmas Fern	Perennial	Fern	Shade, Part-shade	Moist
<i>Prunus serotina</i>	Black Cherry, Wild Black Cherry, Rum Cherry	Perennial	Tree	Sun, Shade, Part-shade	Moist, Dry
<i>Prunus virginiana</i>	Chokecherry, Common Chokecherry, Choke Cherry	Perennial	Tree	Sun, Shade, Part-shade	Moist, Dry
<i>Pteridium aquilinum</i>	Western Bracken Fern, Bracken Fern, Western Bracken, Bracken	Perennial	Herb, Fern	Shade, Part-shade	Wet, Moist, Dry
<i>Quercus alba</i>	White Oak, Northern White Oak, Eastern White Oak, Stave Oak, Ridge White Oak, Forked-leaf White Oak	Perennial	Tree	Sun, Shade, Part-shade	Moist, Dry
<i>Quercus coccinea</i>	Scarlet Oak, Red Oak	Perennial	Tree	Sun	Moist
<i>Quercus macrocarpa</i>	Bur Oak, Burr Oak, Savanna Oak, Overcup Oak, Prairie Oak, Mossy-cup Oak, Mossy-overcup Oak, Blue Oak	Perennial	Tree	Sun, Shade, Part-shade	Wet, Moist, Dry
<i>Quercus muehlenbergii</i>	Chinkapin Oak, Chinquapin Oak, Chestnut Oak, Yellow Chestnut Oak,	Perennial	Tree		Dry

	Rock Chestnut Oak, Yellow Oak, Rock Oak			Sun, Part-shade	
<i>Quercus palustris</i>	Pin Oak, Swamp Spanish Oak	Perennial	Tree	Sun, Shade, Part-shade	Wet, Moist
<i>Quercus rubra</i> var. <i>ambigua</i>	Northern Red Oak	Perennial	Tree		
<i>Rhododendron arborescens</i>	Smooth Azalea, Sweet Azalea	Perennial	Shrub	Part-shade	Moist
<i>Rhododendron calendulaceum</i>	Flame Azalea	Perennial	Shrub	Part-shade	Moist
<i>Rhododendron maximum</i>	Great Laurel, Wild Rhododendron, Rosebay Rhododendron, White Laurel, Rosebay	Perennial	Shrub	Part-shade	Wet, Moist
<i>Rhododendron prunifolium</i>	Plumleaf Azalea	Perennial	Shrub	Part-shade	Moist
<i>Rhus copallinum</i>	Winged Sumac, Shining Sumac, Flameleaf Sumac, Mountain Sumac, Dwarf Sumac, Wing-rib Sumac, Black Sumac, Upland Sumac	Perennial	Shrub	Sun	Dry
<i>Rosa palustris</i>	Swamp Rose	Perennial	Shrub	Sun, Shade, Part-shade	Wet, Moist
<i>Rudbeckia hirta</i>	Black-eyed Susan, Common Black-eyed Susan, Brown-eyed Susan	Annual	Herb	Sun	Moist, Dry
<i>Rudbeckia laciniata</i>	Green-headed Coneflower, Greenhead Coneflower, Cutleaf Coneflower, Wild Goldenglow, Sochan	Perennial	Herb	Sun, Shade, Part-shade	Moist
<i>Sassafras albidum</i>	Sassafras, White Sassafras, Ague Tree, Cinnamon Wood, Mitten Tree, Saloop, Smelling Stick	Perennial	Tree	Sun, Shade, Part-shade	Moist
<i>Sibbaldiopsis tridentata</i>	Shrubby Five-fingers	Perennial	Herb	Sun	
<i>Silene virginica</i>	Fire Pink, Scarlet Catchfly	Perennial	Herb	Part-shade	Moist, Dry
<i>Silphium perfoliatum</i>	Cup Plant, Indian Cup	Perennial	Herb	Sun	Wet, Moist, Dry
<i>Sorbus americana</i>	American Mountain Ash, American Mountain-ash	Perennial	Tree	Sun, Shade, Part-shade	Moist, Dry
<i>Symphotrichum novae-angliae</i>	New England Aster, New England American-aster	Perennial	Herb	Part-shade	Moist

<i>Thuja occidentalis</i>	Arborvitae, Eastern Arborvitae, Northern White Cedar	Perennial	Tree	Sun, Shade, Part-shade	Moist, Dry
<i>Tiarella cordifolia</i>	Heartleaf Foamflower, Heart-leaf Foamflower	Perennial	Herb	Shade	Moist
<i>Tilia americana</i>	American Basswood, American Linden, Lime Tree, Bee Tree	Perennial	Tree	Sun, Shade, Part-shade	Moist, Dry
<i>Tilia americana</i> var. <i>heterophylla</i>	American Basswood, White Basswood, Linden	Perennial	Tree	Part-shade	
<i>Tsuga canadensis</i>	Eastern Hemlock	Perennial	Tree	Shade, Part-shade	Moist
<i>Vaccinium angustifolium</i>	Lowbush Blueberry, Late Lowbush Blueberry	Perennial	Shrub	Sun, Shade, Part-shade	Moist, Dry
<i>Viburnum lentago</i>	Nannyberry, Blackhaw, Sweet Viburnum, Sheepberry	Perennial	Shrub	Sun, Shade, Part-shade	Moist
<i>Viola pedata</i>	Birdfoot Violet, Bird's-foot Violet, Bird-foot Violet	Perennial	Herb	Shade, Part-shade	Dry
<i>Viola sororia</i>	Missouri Violet, Common Blue Violet, Hooded Blue Violet, Florida Violet, Meadow Violet	Annual	Herb	Sun, Part-shade	Moist



## APPENDIX B

# PROHIBITED AND REGULATED INVASIVE PLANTS NYSDEC

*Name*

*Latin Name*

### Terrestrial Plants

Amur Cork Tree	Phellodendron amurense
Amur Honeysuckle	Lonicera maackii
Autumn Olive	Elaeagnus umbellata
Beach Vitex	Vitex rotundifolia
Black Locust	Robinia pseudoacacia
Black Swallow-wort	Cynanchum louiseae (C. nigrum, Vincetoxicum nigrum)
Bohemian Knotweed	Reynoutria x bohemica (Fallopia x bohemica, Polygonum x bohemica)
Border Privet	Ligustrum obtusifolium
Broad-leaved Pepper-grass	Lepidium latifolium
Burning Bush	Euonymus alatus
Canada Thistle	Cirsium arvense (C. setosum, C. incanum, Serratula arvensis)
Chinese Lespedeza	Lespedeza cuneata
Chinese Silver Grass	Miscanthus sinensis
Chinese Yam	Dioscorea polystachya (D. batatas)
Cogon Grass	Imperata cylindrica (I. arundinacea, Lagurus cylindricus)
Common Buckthorn	Rhamnus cathartica
Cup-plant	Silphium perfoliatum
Cut-leaf Teasel	Dipsacus laciniatus
Cypress Spurge	Euphorbia cyparissias
Fly Honeysuckle	Lonicera x bella
Garden Loosestrife	Lysimachia vulgaris
Garlic Mustard	Alliaria petiolata
Giant Hogweed	Heracleum mantegazzianum
Giant Knotweed	Reynoutria sachalinensis (Fallopia sachalinensis, Polygonum sachalinensis)
Golden Bamboo	Phyllostachys aurea
Gray Florist's Willow	Salix atrocinerea
Japanese Angelica Tree	Aralia elata
Japanese Barberry	Berberis thunbergii
Japanese Chaff Flower	Achyranthes japonica
Japanese Honeysuckle	Lonicera japonica
Japanese Hops	Humulus japonicus
Japanese Knotweed	Reynoutria japonica (Fallopia japonica, Polygonum cuspidatum)
Japanese Stilt Grass	Microstegium vimineum
Japanese Virgin's Bower	Clematis terniflora
Kudzu	Pueraria montana
Leafy Spurge	Euphorbia esula
Lesser Celandine	Ficaria verna (Ranunculus ficaria)
Mile-a-minute Weed	Persicaria perfoliata (Polygonum perfoliatum)
Morrow's Honeysuckle	Lonicera morrowii
Mugwort	Artemisia vulgaris
Multiflora Rose	Rosa multiflora
Narrowleaf Bittercress	Cardamine impatiens



## APPENDIX B

# PROHIBITED AND REGULATED INVASIVE PLANTS

## NYSDEC

Norway Maple	Acer platanoides
Oriental Bittersweet	Celastrus orbiculatus
Pale Swallow-wort	Cynanchum rossicum (C. medium, Vincetoxicum medium, V. rossicum)
Porcelain Berry	Ampelopsis brevipedunculata
Slender False Brome	Brachypodium sylvaticum
Small Carpetgrass	Arthraxon hispidus
Spotted Knapweed	Centaurea stoebe (C. biebersteinii, C. diffusa, C. maculosa misapplied, C. xpsammogena)
Sycamore Maple	Acer pseudoplatanus
Tartarian Honeysuckle	Lonicera tatarica
Wavyleaf Basketgrass	Oplismenus hirtellus
Wild Chervil	Anthriscus sylvestris
Wineberry	Rubus phoenicolasius
Winter Creeper	Euonymus fortunei
Yellow Groove Bamboo	Phyllostachys aureosulcata

### Wetland Plants

Common Reed Grass	Phragmites australis
Marsh Dewflower	Murdannia keisak
Purple Loosestrife	Lythrum salicaria
Reed Manna Grass	Glyceria maxima
Smooth Buckthorn	Frangula alnus (Rhamnus frangula)
Yellow Iris	Iris pseudacorus

### Aquatic Plants

Brazilian Waterweed	Egeria densa
Broadleaf Water-milfoil Hybrid	Myriophyllum heterophyllum x
Curly Pondweed	M. laxum
Eurasian Water-milfoil	Potamogeton crispus
Fanwort	Myriophyllum spicatum
Floating Primrose	Cabomba caroliniana
Willow Frogbit	Ludwigia peploides
Hydrilla/ Water	Hydrocharis morsus-ranae
Thyme Parrot-feather	Hydrilla verticillata
Uruguayan	Myriophyllum aquaticum
Primrose Willow	Ludwigia hexapetala (L. grandiflora)
Water Chestnut	Trapa natans
Yellow Floating Heart	Nymphoides peltata



## APPENDIX B

# RECOMMENDED PLANT LISTS

<i>Name</i>	<i>Latin Name</i>	<i>Type</i>
<b>Broccoli Tree &amp; Lawn Care, Butterfly Garden</b>		
Aster	Aster dumosus	Perennial
Butterfly Bush	Buddleia davidii 'buddleja buzz'	Shrub
Coreopsis	Coreopsis 'moonbeam'	Perennial
Purple Coneflower	Echinacea purpurea 'Kim's Knee High'	Perennial
Border Forsythia	Forsythia X intermedia 'lynwood gold'	Shrub
Blue Oat Grass	Helictotrichon sempervirens	Grass
Black Eyed Susan	Rudbeckia fulgida "Goldsturm"	Perennial
May Night Salvia	Salvia x superba 'Mainacht'	Perennial
<b>Broccoli, Fragrance Garden</b>		
Hosta	Hosta plantaginea	Perennial
Sweet Pepperbush	Clethra alnifolia	Shrub
Lavender	Lavendula angustifolia	Perennial
Catmint	Nepeta racemosa 'Walker's Low'	Perennial
Garden Phlox	Phlox paniculata 'Bartwelve'	Perennial
Summer Phlox	Phlox paniculata	Perennial
Prairie Dropseed	Sporobolus heterolepis	Grass
Snowberry	Symphoricarpos albus	Shrub
Dwarf Korean Lilac	Syringa meyeri 'Palibin'	Shrub
<b>Broccoli, Collection Garden</b>		
Blueberry	Corymbosum 'Northland'	Shrub
Tufted Hair Grass	Deschampsia cespitosa	Grass
Dwarf Blue Spruce	Picea pungens 'Globosa'	Shrub
Mugo Pine	Pinus mugo 'Pumilio'	Shrub
Christmas Fern	Polystichum acrostichoides	Fern
Thornless Raspberry	Rubus idaeus 'Raspberry Shortcake'	Shrub
Thornless Blackberry	Rubus spp. 'Triple Crown'	Shrub
Black Eyed Susan	Rudbeckia fulgida "Goldsturm"	Perennial
<b>Broccoli, Shade Garden</b>		
Lady Fern	Athyrium	
Bluewood Aster	Aster cordifolius	
Chinese Astilbe	Astilbe chinensis	
Inland Sea Oats	Uniola latifolia	
Bailey Redstem Dogwood	Cornus sericea 'Baileyi'	
Heuchera	Heuchera cylindrica	
Creeping Phlox	Phlox subulata	



APPENDIX B

RECOMMENDED PLANT LISTS

Name

Latin Name

Type

GI Retrofit Manual,  
Rain Garden

River Birch	Betula nigra	Tree
Green Pillar Pin Oak	Quercus palustris 'Green Pillar'	Deciduous Tree
Goldfinger Potentilla	Potentilla fruticosa 'Goldfinger'	Shrub
Hofer's Blue Yucca	Yucca filamentosa 'Hofer's Blue'	Shrub
Stella D'Oro Daylily	Hemerocallis stella D'Oro	Shrub
Blue Flag Iris	Iris versicolor	Shrub
Summer Phlox	Phlox paniculata	Shrub
Black Eyed Susan	Rudbeckia fulgida "Goldsturm"	Shrub
Soft Rush	Juncus effusus	Shrub
Button Bush	Cephalanthus occidentalis	Shrub
Tufted Hair Grass	Deschampsia cespitosa	Grass
Purple Coneflower	Echinacea purpurea 'Kim's Knee High'	Perennial
Iris	Iris Spuria	Perennial
Blazing Star	Liatris spicata	Perennial
Cardinal Flower	Lobelia cardinalis	Perennial
Great Blue Lobelia	Lobelia siphilitica	Perennial
Switch Grass	Panicum virgatum	Grass
Dwarf Arctic Willow	Salix purpurea 'nana'	Shrub

Henrietta, NY, Vegetated Swale

Black Alder	Alnus glutinosa
Paperbark Maple	Acer griseum
Red Maple	Acer rubrum 'Red Sunset'
Heritage' River Birch	Betula nigra 'Heritage'
Hackberry	Celtis occidentalis
Black Tupelo	Nyssa sylvatica
Swamp White Oak	Quercus bicolor
Lacebark Elm	Ulnus parvifolia
Red-Osier Dogwood	Cornus sericea
Dwarf Forsythia	Forsythia virid. 'Broxensis'
Witch Hazel	Hamamelis virginiana
Grow-Lo Sumac	Rhus aromatica
Meyer Lilac	Syringa meyeri
Scarlet Elder	Sambucus pubens
David Viburnum	Viburnum x. juddii
Judd Viburnum	Viburnum davidi
New England Aster	Aster novae-angliae
Butterfly Bush	Buddleia davidii 'Pink Delight'
Slough Sedge	Carex obnupta
Joe Pye Weed	Eupatorium maculatum





APPENDIX B

RECOMMENDED PLANT LISTS

Dwarf Horsetail	Equisetum scorpioides
Saint John’s Wort	Hypericum calychnum
Day Lily	Hemerocallis ‘Stella de Oro’
Blue Flag Iris	Iris versicolor
Variegated Iris	Iris ensata ‘Variegata’
Soft Rush	Juncus effusus
Cardinal Flower	Lobelia cardinalis
Shasta Daisy	Leucanthemum superbum ‘No. Lights’
Monkey Flower	Mimulus ringens
Maiden Grass	Miscanthus sinensis ‘Morning Light’
Cinnamon Fern	Osmunda cinnamomea
Sensitive Fern	Onoclea sensibilis
Christmas Fern	Polystichum acrostichoides
Fountain Grass	Pennisetum alopecuroides
Japanese Painted Fern	Athyrium n. ‘Pictum’
Black-Eyed Susan	Rudbeckia fulgida ‘Goldsturm’
Dwarf Cattail	Typha minima
Wild Crocus	Crocus tommasinianus ‘Albus’
Wild Crocus	Crocus tommasinianus ‘Barr’s Purple’
Dutch Crocus	Crocus vernus ‘Remembrance’
Daffodil (yellow)	Narcissus ‘Dutch Master’
Daffodil (white)	Narcissus ‘Mount Hood’

Cornell University, Salt Tolerance

Trident Maple	Acer buergerianum	Tree
Red Maple; Scarlet Maple; Swamp Maple	Acer rubrum	Tree
Amur Maple	Acer tataricum ssp. ginnala	Tree
River Birch; Red Birch	Betula nigra	Tree
Hackberry; Sugarberry	Celtis occidentalis	Tree
Cockspur Hawthorn	Crataegus crus-galli	Tree
Washington Hawthorn	Crataegus phaenopyrum	Tree
Winter King Hawthorn	Crataegus viridis ‘Winter King’	Tree
Hardy Rubber Tree	Eucommia ulmoides	Tree
Ginkgo; Maidenhair Tree	Ginkgo biloba	Tree
Common Honeylocust; Honey Locust	Gleditsia triacanthos	Tree
Kentucky Coffeetree	Gymnocladus dioica	Tree
Golden-rain Tree; Varnish Tree	Koeleruteria paniculata	Tree
Amur Maackia	Maackia amurensis	Tree
Osage Orange; Boxwood	Maclura pomifera	Tree
Flowering Crabapple	Malus spp.	Tree
Pepperidge; Sour Gum; Black Gum; Tupelo	Nyssa sylvatica	Tree
Flowering Cherry ‘Accolade’	Prunus ‘Accolade’	Tree
Sargent Cherry	Prunus sargentii	Tree
Callery Pear	Pyrus calleryana	Tree
Saw-tooth Oak	Quercus acutissima	Tree



APPENDIX B

RECOMMENDED PLANT LISTS

Swamp White Oak	Quercus bicolor	Tree
Bur Oak; Mossycup Oak	Quercus macrocarpa	Tree
Chinkapin Oak	Quercus muehlenbergii	Tree
Willow Oak	Quercus phellos	Tree
English Oak; Truffle Oak; Pedunculate Oak	Quercus robur	Tree
Red Oak; Northern Red Oak	Quercus rubra	Tree
Black Locust	Robinia pseudoacacia	Tree
Japanese Pagoda Tree; Scholar-Tree	Styphnolobium japonicum	Tree
Japanese Tree Lilac	Syringa reticulata	Tree
Bald Cypress	Taxodium distichum	Tree
Hybrid Elm 'Accolade'	Ulmus 'Accolade'	Tree
Hybrid Elm 'Frontier'	Ulmus 'Frontier'	Tree
American Elm	Ulmus americana	Tree
Chinese Elm; Lacebark Elm	Ulmus parvifolia	Tree
Hybrid Elms	Ulmus spp.	Tree

Cornell University, Trees Suitable for Use in CU Structural Soil

Hedge Maple	Acer campestre	Tree
Miyabe Maple	Acer miyabei	Tree
European Hornbeam	Carpinus betulus	Tree
Catalpa; Indian Bean	Catalpa speciosa	Tree
Hackberry; Sugarberry	Celtis occidentalis	Tree
Eastern Redbud	Cercis canadensis	Tree
Corneliancherry Dogwood; Cornelian Cherry	Cornus mas	Tree
Turkish Filbert; Turkish Hazel	Corylus colurna	Tree
American Smoketree	Cotinus obovatus	Tree
Cockspur Hawthorn	Crataegus crus-galli	Tree
Washington Hawthorn	Crataegus phaenopyrum	Tree
Winter King Hawthorn	Crataegus viridis 'Winter King'	Tree
Hardy Rubber Tree	Eucommia ulmoides	Tree
Ginkgo; Maidenhair Tree	Ginkgo biloba	Tree
Common Honeylocust; Honey Locust	Gleditsia triacanthos	Tree
Kentucky Coffeetree	Gymnocladus dioicus	Tree
Golden-rain Tree; Varnish Tree	Koelreuteria paniculata	Tree
Amur Maackia	Maackia amurensis	Tree
Osage Orange; Boxwood	Maclura pomifera	Tree
Flowering Crabapple	Malus spp.	Tree
Persian Parrotia	Parrotia persica	Tree
London Planetree	Platanus x acerifolia	Tree
Callery Pear	Pyrus calleryana	Tree
Swamp White Oak	Quercus bicolor	Tree
Bur Oak; Mossycup Oak	Quercus macrocarpa	Tree
Chinkapin Oak	Quercus muehlenbergii	Tree
English Oak; Truffle Oak; Pedunculate Oak	Quercus robur	Tree



APPENDIX B

RECOMMENDED PLANT LISTS

Black Locust	Robinia pseudoacacia	Tree
Korean Mountain Ash	Sorbus alnifolia	Tree
Japanese Pagoda Tree; Scholar-Tree	Styphnolobium japonicum	Tree
Japanese Tree Lilac	Syringa reticulata	Tree
American Linden; Basswood	Tilia americana	Tree
Littleleaf Linden; Small-leaved Lime	Tilia cordata	Tree
Silver Linden	Tilia tomentosa	Tree
Crimean Linden	Tilia x euchlora	Tree
Hybrid Elm 'Accolade'	Ulmus 'Accolade'	Tree
Hybrid Elm 'Frontier'	Ulmus 'Frontier'	Tree
American Elm	Ulmus americana	Tree
Chinese Elm; Lacebark Elm	Ulmus parvifolia	Tree
Hybrid Elms	Ulmus spp.	Tree
Japanese Zelkova; Saw-leaf Zelkova	Zelkova serrata	Tree

Cornell University, Easy to Transplant Bare Root Trees

Hedge Maple	Acer campestre	Tree
Miyabe Maple	Acer miyabei	Tree
Red Maple; Scarlet Maple; Swamp Maple	Acer rubrum	Tree
Sugar Maple; Rock Maple; Hard Maple	Acer saccharum	Tree
Amur Maple	Acer tataricum ssp. ginnala	Tree
Freeman Maple	Acer x freemanii	Tree
Catalpa; Indian Bean	Catalpa speciosa	Tree
Yellowwood	Cladrastis kentukea	Tree
Corneliancherry Dogwood; Cornelian Cherry	Cornus mas	Tree
Common Honeylocust; Honey Locust	Gleditsia triacanthos	Tree
Kentucky Coffeetree	Gymnocladus dioicus	Tree
Golden-rain Tree; Varnish Tree	Koelreuteria paniculata	Tree
Amur Maackia	Maackia amurensis	Tree
Flowering Crabapple	Malus spp.	Tree
Persian Parrotia	Parrotia persica	Tree
London Planetree	Platanus x acerifolia	Tree
Flowering Cherry 'Accolade'	Prunus 'Accolade'	Tree
Sargent Cherry	Prunus sargentii	Tree
Chokecherry	Prunus virginiana	Tree
Callery Pear	Pyrus calleryana	Tree
Swamp White Oak	Quercus bicolor	Tree
Red Oak; Northern Red Oak	Quercus rubra	Tree
Black Locust	Robinia pseudoacacia	Tree
Korean Mountain Ash	Sorbus alnifolia	Tree
Japanese Tree Lilac	Syringa reticulata	Tree
American Linden; Basswood	Tilia americana	Tree
Littleleaf Linden; Small-leaved Lime	Tilia cordata	Tree
Crimean Linden	Tilia x euchlora	Tree



APPENDIX B

RECOMMENDED PLANT LISTS

Hybrid Elm ‘Accolade’	Ulmus ‘Accolade’	Tree
American Elm	Ulmus americana	Tree
Hybrid Elms	Ulmus spp.	Tree

Fayetteville, NY, Streetscape Plants

Robin Hill Serviceberry	Amelanchier x grandiflora ‘Robin Hill’	Deciduous Tree
Eastern Redbud	Cercis canadensis	Deciduous Tree
Pink Princess Crabapple	Malus ‘Pink Princess’	Deciduous Tree
Japanese Tree Lilac	Syringa reticulata	Deciduous Tree
Kelsey Red Twig Dogwood	Cornus sericea ‘Kelsey’	Deciduous Shrub
Red Sprite Winterberry	Ilex verticallata ‘Red Sprite’	Deciduous Shrub
New England Aster	Aster Novae-angliae	Herbaceous
Lurid Sedge	Carex lurida	Herbaceous
Cranesbill	Geranium maculatum	Herbaceous
Happy Returns Daylily	Hemerocalis ‘Happy Returns’	Herbaceous
Blue Flag Iris	Iris versicolor	Herbaceous
Soft Rush	Juncus effusus	Herbaceous
Blazing Star	Liatris spicata	Herbaceous

Rochester City Hall, Streetscape & Green Infrastructure

River Birch	Betula nigra	Deciduous Tree
Green Pillar Pin Oak	Quercus palustris ‘Green Pillar’	Deciduous Tree
Goldfinger Potentilla	Potentilla fruticosa ‘Goldfinger’	Shrub
Hofer’s Blue Yucca	Yucca filamentosa ‘Hofer’s Blue’	Shrub
Stella D’Oro Daylily	Hemerocallis stella d’oro	Perennial
Blue Flag Iris	Iris versicolor	Perennial
Blazing Star	Liatris spicata	Perennial
Summer Phlox	Phlox paniculata	Perennial
Black Eyed Susan	Rudbeckia fulgida	Perennial
Soft Rush	Juncus effusus	Grass

RMSC, Green Infrastructure

Red Maple	Acer rubrum	Tree
Allegheny Serviceberry	Amelanchier laevis ‘Prince Charles’	Tree
River Birch	Betula nigra	Tree
Swamp White Oak	Quercus bicolor	Tree
Buttonbush	Cephalanthus occidentalis	Shrub
Bailey Redstem Dogwood	Cornus sericea ‘Bailey’	Shrub
Dwarf Arctic Willow	Salix purpurea ‘Nana’	Shrub
New England Aster	Aster novae-angliae	Perennials and Grasses
Lurid Sedge	Carex lurida	Perennials and Grasses



APPENDIX B

RECOMMENDED PLANT LISTS

Tufted Hair Grass
Purple Coneflower
Daylily
Iris
Soft Rush
Shasta Daisy
Blazing Star
Cardinal Flower
Switchgrass
Summer Phlox
Black Eyed Susan
Little Bluestem
Upland White Aster

Deschampsia cespitosa
Echinacea purpurea
Hemerocalis
Iris versicolor
Juncus effusus
Leucanthemum x superbum
Liatris spicata
Locelia cardinalis
Panicum virgatum
Phlox paniculata
Rudbeckia fulgida
Schizachyrium scoparium
Solidago Ptarmicoides

Perennials and Grasses
Perennials and Grasses
Perennials and Grasses
Perennials and Grasses
Perennials and Grasses
Perennials and Grasses
Perennials and Grasses
Perennials and Grasses
Perennials and Grasses
Perennials and Grasses
Perennials and Grasses
Perennials and Grasses
Perennials and Grasses

Wright Park, Plant Schedule

Black Alder
Hackberry
Tulip Tree
Red Oak
Bailey Redstem Dogwood
Dwarf Arctic Willow
Tufted Hair Grass
Daylily
Iris

Alnus gultinosa
Celtis occidentalis
Liriodendron tulipifera
Quercus rubra
Cornus sericea 'Bailey'
Salix purpurea 'Nana'
Deschampsia cespitosa
Hemerocalis
Iris versicolor

Tree
Tree
Tree
Tree
Shrub
Shrub
Grass
Perennial
Perennial



APPENDIX C

PROJECT COORDINATION

COMMUNITY PARTICIPATION

Planning is a collaborative process, and should not be done in a vacuum. New York State has identified principles to guide community planning, which state that planning should be continuous, comprehensive, participatory, and coordinated. Participation from a variety of members of the community is not just a requirement, but a critical element of a successful plan. See Table 2 for a list of meetings that were a part of this project.

PROJECT ADVISORY COMMITTEE

The planning process for this study included outreach to key stakeholders. A project advisory committee, comprised of local stakeholders from a variety of perspectives, including officials, consultants, contractors, and developers. This was of significant importance to the composition of this document to balance rigidity and flexibility in each guideline to appropriately elevate the standard of development in the Town.

Table 2. Project Meeting Schedule

Table with 3 columns: DATE, MEETING, PURPOSE. Rows include dates from 05.17.18 to 05.09.19 and meeting types like Kick-Off, PAC #1, PAC #2, PAC #3.

PROJECT ADVISORY COMMITTEE MEMBERS

Table with 2 columns: Name, Affiliation. Lists members like Robert Barley, Patty Brill, Lauri Broccolo, Sarah Hogan, Chris Martin, Peter Minotti, Hanna Quigley, Noreen Riordan, Tom Robinson, Bill Santos, Steve Schultz, Michael Trojian and their affiliations.



### APPENDIX D

# SITE CONTEXT

## TOWN DOCUMENT ANALYSIS

As a part of this update, extensive review and comparison of Town documents to other case studies were important to understand and evaluate the current approach to site design, and identify gaps between the current standard, vision of the Town of Henrietta, and recommended standards of sustainable design. Town document review included the following, with consistent standards and procedure described below:

- Henrietta Town Code
- Town of Henrietta Multiple Dwelling Design Guidelines
- 2011 Comprehensive Plan Update
- Town of Henrietta Site Plan Checklist
- Town Code Rural Residential District
- Tree Inventory
- Comprehensive Lane Use Plan, 2019 Update

## RESOURCES FOR SITE DESIGN GUIDELINES

“Landscape Guidelines.” City of Alexandria, Virginia. April 2007.

“Green Stormwater Infrastructure Landscape Design Guidebook.” Philadelphia Water Department. 2014.

“Administrative Landscaping Guidelines.” City of Marysville Washington Community Development Department. 2 December 2013.

“Town of Winter Park Landscape Design Regulations and Guidelines.” Town of Winter Park. 19 December 1994.

“Sustainable Landscape Design Guidelines.” University of Pittsburgh. 5 April 2017.

Barton & Loguidice, P.C. “Site and Architectural Design Standards for Commercial Design Overlay District.” Village of Chittenango, Madison County, New York. February 2010.

“Design & Development Guide.” Town of Henrietta, New York. 2019.





### APPENDIX D

# SITE CONTEXT

## TOWN LANDSCAPE ASSESSMENT

Comparing Town documents to current studies and ongoing comprehensive Town goals unveils how existing documents have resulted in site designs which meet Town expectations, and where there are gaps between the recommendations in these documents and resulting non-standard site designs. An assessment of priority needs for Town of Henrietta landscape guidelines was compiled after a tour of several developments in Henrietta and discussion with the project committee.

- There is a need to improve planting design regarding tree caliper, spacing, and specification. A new plant list is recommended, as well as standard Town plant details.
- Inspections end too early, and often not thorough enough. Interns or partnerships with local universities that specialize in dendrology are recommended.
- Clay soils are a limitation in the Town of Henrietta, adding constraints on vegetated matter. There is a need for a guideline regarding appropriate soil structuring and specification.
- Successful stormwater management practices lack longevity in several parts of the town, especially with the amount of impermeable space coverage by parking lots. There is a need for a guideline regarding best practices for drainage and infiltration, as well as land banking.
- Landscaped areas are often too narrow to provide functional benefits to the landscape and transitional spaces. A need for a guideline regarding buffers and hardscape to softscape proportioning is necessary.
- Maintenance plans are disregarded at many sites in Henrietta. There should be a guideline describing best management practices for landscape design longevity and resiliency, as well as enforcement.

## WORKSHOP #2: REVIEW OF HENRIETTA LANDSCAPE TOUR

### KEY COMMENTS AND OBSERVATIONS

**Businesses and buffers:** constantly pruning plants or clustering too close, need a standard tree detail or list with tough species that do not easily break, or grow at a high canopy height that does not take away from view of businesses, suggest landscape buffer between businesses to break up continuation and screen as a benefit. Think about maturity and visualization.

**Land Bank:** focus on converting parking lots – “sea of asphalt” – to conservation areas. For example, if a contractor claims they have no space for landscape on site, land bank the resources into excavating a parking lot section that is unused into a landscaped space.

**Maintenance Time:** 2 year with 10% landscape cost withheld by town, should be 3-4 years minimum to ensure growth of trees, especially those placed in with a larger caliper or poor health to start. Town does not have the ability to enforce and oversee dead trees are replaced or landscape preserved with turn-over development.

**Mulching:** in many parts of the town, mulch piles below trees are piled above the root flare, which causes damage to tree growth- “mulch volcanoes” – as nicknamed. Need typical town detail.

**Recommend Interns:** inspection crew undereducated for understanding health of landscape, too expensive to send out staff, so send out educated students in arboriculture.

**Required landscape space:** often scattered providing no ecosystem services, no room for growth, needs to be clustered and regulated to function instead of present to meet requirement. Consider clay soil.

**Role of Conservation Board:** how can they get involved in commercial development without becoming inflexible with standards and expectations that scare away developers. Player versus stakeholder.

**Soft Edges and stormwater management:** need to fully understand the purpose, components, and function of these systems, including habitat value and efficiency. Educational pieces to the guidelines including interpretive panels and standard town details should be available.

**Tidy versus natural plant growth:** plant variety heights and appropriate settings for naturalized vegetation versus manicured vegetation. Drop curb detail should be encouraged.



BUS ROUTE, TOWN OF HENRIETTA.



APPENDIX E

MAINTENANCE SCHEDULE

ONONDAGA COUNTY SAVE THE RAIN

<i>Maintenance Task</i>	<i>Recommended Frequency</i>	<i>Description</i>
Porous Pavement Vacuuming	Semi-annually (2x/year) for concrete, asphalt and flexible pavement; annually in spring for pavers	Porous pavement surfaces require vacuuming to remove debris that may clog the permeable layers/voids and prevent infiltration.
Porous Pavement Power Washing	Once every three years (or as necessary)	Power washing restores permeability and should follow porous pavement vacuuming. Porous pavers should not be power washed.
Porous Paver Maintenance (Restoring Aggregate)	As needed when gravel infill is not within 1/2 inch of the paver surface, immediately following vacuuming	This task refers to the refilling of voids between pavers with additional aggregate material to replace any material that has been lost by vacuuming and/or due to natural migration, settlement, and erosion.
Winter Maintenance for Porous Pavements	As necessary during Winter	Porous pavement surfaces require modified plowing and salting practices during the winter months when snow is present.
Stormwater Structure Cleaning	Semi-annually (2x/year)	Stormwater Structure Cleaning refers to removing debris or clogged materials and vacuuming the interior of the structure.
Inlet Filter Insert Cleaning or Filter Insert Pouch Replacement	Clean Quarterly (4x/year) until it is determined a particular inlet requires less frequent cleaning; Replace annually	Filter inserts need to be cleaned with an industrial vacuum to remove debris and prevent clogging.
Green Roof Maintenance	Spring and Fall, after initial 2-3 year establishment period; must adhere to the project specifications/warranty provisions	Remove debris, weed, prune plants, replenish, fertilize if needed. Follow project specific maintenance plan, if prepared and approved.
River-stone Edge Maintenance	Annually in Spring	Remove debris, weed, rake, replenish as needed.
Tree General Maintenance, Weeding, Mulching, Soil Amendment	Year 1 is covered by Contractor’s maintenance agreement/warranty; Year weeding occurs 3 times/year; mulching occurs annually in Spring	Tree inspection covers an initial tree health assessment, followed by tree pit weeding and tree pit mulching.
Landscaping Areas General Maintenance, Weeding, Mulching	Inspection: 1x/year; Weeding to occur 3x/year (spring clean-up; Summer maintenance; fall put to bed); Mulching to occur 1x/year in Spring	Landscape inspection covers an initial health assessment of the plantings, followed by trash removal, weeding, and mulching.
Meadow Inspection, Control of Invasive Species	Monitor meadow monthly during growing season for invasive species during first 2 to 3 years	Inspect and monitor the meadow for invasive species.
Tree Watering	Year 1 is covered by Contractor’s maintenance agreement/warranty; Year 2: water weekly in the absence of rain; Years 3+: only as necessary in during extended periods of drought	Tree and landscape watering refers to watering during establishment in Years 1 and 2 and as necessary during extended periods of drought.
Landscape Watering	Year 1 is covered by Contractor’s maintenance agreement/warranty; Year 2 and 3: water during the first 4-6 weeks of the growing season, and then only during extended periods of drought	Tree and landscape watering refers to watering during establishment in Years 1 and 2 and as necessary during extended periods of drought.
Tree Pruning	Year 1 is covered by Contractor’s maintenance agreement/warranty; One-time per year in Year 3 (Fall or Spring depending on species); One time per year in years 5, 8, 12, 18, 24, 30, 36, 44, 52, 60	Tree and landscape pruning refers to annual pruning to maintain aesthetics and promote tree vigor.
Landscape Pruning	Year 1 is covered by Contractor’s maintenance agreement/warranty; 1x/year beginning in Year 2 depending on plant type	Tree and landscape pruning refers to annual pruning to maintain aesthetics and promote tree vigor.
Meadow Mowing	Year 1: once a month from Apr-Nov; Year 2: Once in Fall; Year 3 and beyond: once every 2 years in Spring	Mowing helps prevent/control woody plant and weed establishment, and helps to disperse seeds of desirable species.
Landscape Replacement (excludes Trees)	Spring and Fall, as a corrective maintenance task that should only be performed on an as needed basis	Replace missing, dead, or diseased shrubs and herbaceous plant material.



APPENDIX F

# LANDSCAPE INSPECTION FORM

APPENDIX G NYS STORMWATER MANAGEMENT DESIGN MANUAL

**Stormwater Pond/Wetland Operation, Maintenance and Management Inspection Checklist**

Project \_\_\_\_\_

Location: \_\_\_\_\_

Site Status: \_\_\_\_\_

Date: \_\_\_\_\_

Time: \_\_\_\_\_

Inspector: \_\_\_\_\_

Maintenance Item	Satisfactory/ Unsatisfactory	Comments
<b>1. Embankment and emergency spillway (Annual, After Major Storms)</b>		
1. Vegetation and ground cover adequate		
2. Embankment erosion		
3. Animal burrows		
4. Unauthorized planting		
5. Cracking, bulging, or sliding of dam		
a. Upstream face		
b. Downstream face		
c. At or beyond toe		
downstream		
upstream		
d. Emergency spillway		
6. Pond, toe & chimney drains clear and functioning		
7. Seeps/leaks on downstream face		
8. Slope protection or riprap failure		
9. Vertical/horizontal alignment of top of dam "As-Built"		

Maintenance Item	Satisfactory/ Unsatisfactory	Comments
10. Emergency spillway clear of obstructions and debris		
11. Other (specify)		
<b>2. Riser and principal spillway (Annual)</b>		
Type: Reinforced concrete _____ Corrugated pipe _____ Masonry _____		
1. Low flow orifice obstructed		
2. Low flow trash rack. a. Debris removal necessary		
b. Corrosion control		
3. Weir trash rack maintenance a. Debris removal necessary		
b. corrosion control		
4. Excessive sediment accumulation insider riser		
5. Concrete/masonry condition riser and barrels a. cracks or displacement		
b. Minor spalling (<1" )		
c. Major spalling (rebars exposed)		
d. Joint failures		
e. Water tightness		
6. Metal pipe condition		
7. Control valve a. Operational/exercised		
b. Chained and locked		
8. Pond drain valve a. Operational/exercised		
b. Chained and locked		
9. Outfall channels functioning		
10. Other (specify)		

Maintenance Item	Satisfactory/ Unsatisfactory	Comments
<b>3. Permanent Pool (Wet Ponds) (monthly)</b>		
1. Undesirable vegetative growth		
2. Floating or floatable debris removal required		
3. Visible pollution		
4. Shoreline problem		
5. Other (specify)		
<b>4. Sediment Forebays</b>		
1. Sedimentation noted		
2. Sediment cleanout when depth < 50% design depth		
<b>5. Dry Pond Areas</b>		
1. Vegetation adequate		
2. Undesirable vegetative growth		
3. Undesirable woody vegetation		
4. Low flow channels clear of obstructions		
5. Standing water or wet spots		
6. Sediment and / or trash accumulation		
7. Other (specify)		
<b>6. Condition of Outfalls (Annual , After Major Storms)</b>		
1. Riprap failures		
2. Slope erosion		
3. Storm drain pipes		
4. Endwalls / Headwalls		
5. Other (specify)		
<b>7. Other (Monthly)</b>		
1. Encroachment on pond, wetland or easement area		



Maintenance Item	Satisfactory/ Unsatisfactory	Comments
2. Complaints from residents		
3. Aesthetics a. Grass growing required		
b. Graffiti removal needed		
c. Other (specify)		
4. Conditions of maintenance access routes.		
5. Signs of hydrocarbon build-up		
6. Any public hazards (specify)		
<b>8. Wetland Vegetation (Annual)</b>		
1. Vegetation healthy and growing Wetland maintaining 50% surface area coverage of wetland plants after the second growing season. (If unsatisfactory, reinforcement plantings needed)		
2. Dominant wetland plants: Survival of desired wetland plant species Distribution according to landscaping plan?		
3. Evidence of invasive species		
4. Maintenance of adequate water depths for desired wetland plant species		
5. Harvesting of emergent plantings needed		
6. Have sediment accumulations reduced pool volume significantly or are plants "choked" with sediment		
7. Eutrophication level of the wetland.		
8. Other (specify)		

**Comments:**

---



---



---



---



---

**Actions to be Taken:**

---

---

---

---

## Infiltration Trench Operation, Maintenance, and Management Inspection Checklist

Project:  
 Location:  
 Site Status:

Date:

Time:

Inspector:

MAINTENANCE ITEM	SATISFACTORY / UNSATISFACTORY	COMMENTS
<b>1. Debris Cleanout (Monthly)</b>		
Trench surface clear of debris		
Inflow pipes clear of debris		
Overflow spillway clear of debris		
Inlet area clear of debris		
<b>2. Sediment Traps or Forebays (Annual)</b>		
Obviously trapping sediment		
Greater than 50% of storage volume remaining		
<b>3. Dewatering (Monthly)</b>		
Trench dewaterers between storms		
<b>4. Sediment Cleanout of Trench (Annual)</b>		
No evidence of sedimentation in trench		
Sediment accumulation doesn't yet require cleanout		
<b>5. Inlets (Annual)</b>		

MAINTENANCE ITEM	SATISFACTORY / UNSATISFACTORY	COMMENTS
Good condition		
No evidence of erosion		
<b>6. Outlet/Overflow Spillway (Annual)</b>		
Good condition, no need for repair		
No evidence of erosion		
<b>7. Aggregate Repairs (Annual)</b>		
Surface of aggregate clean		
Top layer of stone does not need replacement		
Trench does not need rehabilitation		

**Comments:**

---



---



---



---



---



---



---

**Actions to be Taken:**

---



---



---



---



---



---



---

## Bioretention Operation, Maintenance and Management Inspection Checklist

Project:  
 Location:  
 Site Status:

Date:

Time:

Inspector:

MAINTENANCE ITEM	SATISFACTORY / UNSATISFACTORY	COMMENTS
<b>1. Debris Cleanout (Monthly)</b>		
Bioretention and contributing areas clean of debris		
No dumping of yard wastes into practice		
Litter (branches, etc.) have been removed		
<b>2. Vegetation (Monthly)</b>		
Plant height not less than design water depth		
Fertilized per specifications		
Plant composition according to approved plans		
No placement of inappropriate plants		
Grass height not greater than 6 inches		
No evidence of erosion		
<b>3. Check Dams/Energy Dissipaters/Sumps (Annual, After Major Storms)</b>		
No evidence of sediment buildup		

MAINTENANCE ITEM	SATISFACTORY / UNSATISFACTORY	COMMENTS
Sumps should not be more than 50% full of sediment		
No evidence of erosion at downstream toe of drop structure		
<b>4. Dewatering (Monthly)</b>		
Dewaterers between storms		
No evidence of standing water		
<b>5. Sediment Deposition (Annual)</b>		
Swale clean of sediments		
Sediments should not be > 20% of swale design depth		
<b>6. Outlet/Overflow Spillway (Annual, After Major Storms)</b>		
Good condition, no need for repair		
No evidence of erosion		
No evidence of any blockages		
<b>7. Integrity of Filter Bed (Annual)</b>		
Filter bed has not been blocked or filled inappropriately		

**Comments:**

---

---

---

---

---

---

---

---

**Actions to be Taken:**

---

---

---

---

---

---

---

---



## Open Channel Operation, Maintenance, and Management Inspection Checklist

Project:  
 Location:  
 Site Status:

Date:

Time:

Inspector:

MAINTENANCE ITEM	SATISFACTORY/ UNSATISFACTORY	COMMENTS
<b>1. Debris Cleanout (Monthly)</b>		
Contributing areas clean of debris		
<b>2. Check Dams or Energy Dissipators (Annual, After Major Storms)</b>		
No evidence of flow going around structures		
No evidence of erosion at downstream toe		
Soil permeability		
Groundwater / bedrock		
<b>3. Vegetation (Monthly)</b>		
Mowing done when needed		
Minimum mowing depth not exceeded		
No evidence of erosion		
Fertilized per specification		
<b>4. Dewatering (Monthly)</b>		
Dewaterers between storms		

MAINTENANCE ITEM	SATISFACTORY/ UNSATISFACTORY	COMMENTS
<b>5. Sediment deposition (Annual)</b>		
Clean of sediment		
<b>6. Outlet/Overflow Spillway (Annual)</b>		
Good condition, no need for repairs		
No evidence of erosion		

**Comments:**

---

---

---

---

---

---

---

---

---

---

**Actions to be Taken:**

---

---

---

---

---

---

---

---

---

---



APPENDIX F

# LANDSCAPE INSPECTION FORM

UNIVERSITY OF NEW HAMPSHIRE STORMWATER CENTER

# CHECKLIST FOR INSPECTION OF BIORETENTION SYSTEM / TREE FILTERS

Location:

Inspector:

Date:

Time:

Site Conditions:

Date Since Last Rain Event:

Inspection Items	Satisfactory (S) or Unsatisfactory (U)	Comments/Corrective Action
<b>1. Initial Inspection After Planting and Mulching</b>		
Plants are stable, roots not exposed	S      U	
Surface is at design level, typically 4" below overpass	S      U	
Overflow bypass / inlet ( if available) is functional	S      U	
<b>2. Debris Cleanup (2 times a year minimum, Spring &amp; Fall)</b>		
Litter, leaves, and dead vegetation removed from the system	S      U	
Prune perennial vegetation	S      U	
<b>3. Standing Water (1 time a year, After large storm events)</b>		
No evidence of standing water after 72 hours	S      U	
<b>4. Short Circuiting &amp; Erosion (1 times a year, After large storm events)</b>		
No evidence of animal burrows or other holes	S      U	
No evidence of erosion	S      U	
<b>5. Drought Conditions (As needed)</b>		
Water plants as needed	S      U	
Dead or dying plants	S      U	
<b>6. Overflow Bypass / Inlet Inspection (1 times a year, After large storm events)</b>		
No evidence of blockage or accumulated leaves	S      U	
Good condition, no need for repair	S      U	
<b>7. Vegetation Coverage (once a year)</b>		
50 % coverage established throughout system by first year	S      U	
Robust coverage by year 2 or later	S      U	
<b>8. Mulch Depth (if applicable)(once every 2 years)</b>		
Mulch at original design depth after tilling or replacement	S      U	
<b>9. Vegetation Health ( once every 3 years)</b>		
Dead or decaying plants removed from the system	S      U	
<b>10. Tree Pruning (once every 3 years)</b>		
Prune dead, diseased, or crossing branches	S      U	
<b>Corrective Action Needed</b>		<b>Due Date</b>
1.		
2.		
3.		

## Regular Inspection and Maintenance Guidance for Porous Pavements

Regular inspection and maintenance is critical to the effective operation of porous pavement. It is the responsibility of the owner to maintain the pavement in accordance with the minimum design standards. This page provides guidance on maintenance activities that are typically required for these systems, along with the suggested frequency for each activity. Individual systems may have more, or less, frequent maintenance needs, depending on a variety of factors including the occurrence of large storm events, seasonal changes, and traffic conditions.

### Inspection Activities

Visual inspections are an integral part of system maintenance. This includes monitoring pavement to ensure water drainage, debris accumulation, and surface deterioration.

ACTIVITY	FREQUENCY
Check for standing water on the surface of the pavement after a precipitation event. If standing water remains within 30 minutes after rainfall had ended, cleaning of porous pavement is recommended.	2 to 4 times per year, more frequently for high use sites or sites with higher potential for run-on
Vacuum sweeper shall be used regularly to remove sediment and organic debris on the pavement surface. The sweeper may be fitted with water jets.	
Pavement vacuuming should occur during spring cleanup following the last snow event to remove accumulated debris, at minimum.	
Pavement vacuuming should occur during fall cleanup to remove dead leaves, at minimum.	
Power washing can be an effective tool for cleaning clogged areas. This should occur at mid pressure typically less than 500 psi and at an angle of 30 degrees or less.	
Check for debris accumulating on pavement, especially debris buildup in winter. For loose debris, a power/leaf blower or gutter broom can be used to remove leaves and trash.	
Check for damage to porous pavements from non-design loads. Damaged areas may be repaired by use of infrared heating and rerolling of pavement. Typical costs may be 2,000/ day for approximately 500 ft of trench.	

### Maintenance Activities

**Routine preventative cleaning is more effective than corrective cleaning.**

Activity	Frequency
Controlling run-on and debris tracking is key to extending the life of porous surfaces. Erosion and sedimentation control of adjacent areas is crucial. Vacuuming adjacent non porous asphalt can be effective at minimizing run-on.	Whenever vacuuming adjacent porous pavements
Repairs may be needed from cuts of utilities. Repairs can be made using standard (non-porous) asphalt for most damages. Repairs using standard asphalt should not exceed 15% of total area.	As needed
Do not store materials such as sand/salt, mulch, soil, yard waste, and other stock piles on porous surfaces.	
Stockpiled snow areas on porous pavements will require additional maintenance and vacuuming. Stockpiling on snow on porous pavements is not recommended and will lead to premature clogging.	
Damage can occur to porous pavement from non-design loads. Precautions such as clearance bars, signage, tight turning radius, high curbs, and video surveillance may be required where there is a risk off non-design loads.	
Posting of signage is recommended indicating presence of porous pavement. Signage should display limitation of design load (i.e. passenger vehicles only, light truck traffic, etc. as per pavement durability rating.)	

## CHECKLIST FOR INSPECTION OF POROUS PAVEMENTS

Location:

Inspector:

Date:

Time:

Site Conditions:

Date Since Last Rain Event:

Inspection Items	Satisfactory (S) or Unsatisfactory (U)		Comments/Corrective Action
<b>1. Salt / Deicing *Note complete winter maintenance guidance is available at UNHSC</b>			
Use salt only for ice management	S	U	
Piles of accumulated salt removed in spring	S	U	
<b>2. Debris Cleanup (2-4 times a year minimum, Spring &amp; Fall)</b>			
Clean porous pavement to remove sediment and organic debris on the pavement surface via vacuum street sweeper.	S	U	
Adjacent non porous pavement vacuumed	S	U	
Clean catch basins (if available)	S	U	
<b>3. Controlling Run-On (2-4 times a year)</b>			
Adjacent vegetated areas show no signs of erosion and run-on to porous pavement	S	U	
<b>4. Outlet / Catch Basin Inspection (if available) (2 times a year, After large storm events)</b>			
No evidence of blockage	S	U	
Good condition, no need for cleaning/repair	S	U	
<b>5. Poorly Drained Pavement (2-4 times a year)</b>			
Pavement has been pressure washed and vacuumed	S	U	
<b>6. Pavement Condition (2-4 times a year minimum, Spring &amp; Fall)</b>			
No evidence of deterioration	S	U	
No cuts from utilities visible	S	U	
No evidence of improper design load applied	S	U	
<b>7. Signage / Stockpiling (As Needed)</b>			
Proper signage posted indicating usage for traffic load	S	U	
No stockpiling of materials and no seal coating	S	U	

Corrective Action Needed	Due Date
1.	
2.	
3.	



APPENDIX F

LANDSCAPE ASSESSMENT FORM



TOWN OF HENRIETTA

Landscape Guidelines Update

Landscape Assessment Form

Date:

Location:

Landscape type:	Residential	Commercial	Institutional	other	unknown/NA
Project scale: (sq. ft.)	<2,000	2-5,000	5,000-10,000	>10,000	unknown/NA
Project age: (yrs.)	1-3	4-8	9- 15	>15	unknown/NA

CONTEXT (circle which applies)

New construction		yes		no		unknown/NA
Retrofit/re-development		yes		no		unknown/NA
Development on farmland		yes		no		unknown/NA
Relation/transition to adjacent land use	1(worst)	2	3	4	5(best)	unknown/NA
Conserve natural resources	1	2	3	4	5	unknown/NA
Conserve cultural resources	1	2	3	4	5	unknown/NA
Community connectivity	1	2	3	4	5	unknown/NA

COMMENTS

---



---



---



---



---



---



---





### WATER MANAGEMENT

Grading/Drainage/ Erosion control	1(worst)	2	3	4	5(best)	unknown/NA
Irrigation required		yes		no		unknown/NA
Applications of						
Green Infrastructure	1	2	3	4	5	unknown/NA

### SOILS & VEGETATION

Conserve/restore native plant communities	1(worst)	2	3	4	5(best)	unknown/NA
Use native plants	1	2	3	4	5	unknown/NA
Biodiversity	1	2	3	4	5	unknown/NA
Control & manage invasive plants	1	2	3	4	5	unknown/NA
Reduce urban heat island effect	1	2	3	4	5	unknown/NA
Maintainability	1	2	3	4	5	unknown/NA

### GENERAL

Universal Accessibility	1(worst)	2	3	4	5(best)	unknown/NA
Four Season Visual Quality	1	2	3	4	5	unknown/NA

### COMMENTS

---



---



---



---



---



APPENDIX F

SUPPLEMENTAL LANDSCAPE ASSESSMENT FORM
CORNELL UNIVERSITY

1. Site Location \_\_\_\_\_

2. Site Description \_\_\_\_\_

3. Climate

a. USDA Hardiness Zone

\_\_6b \_\_5b \_\_4b \_\_3b
\_\_6a \_\_5a \_\_4a \_\_3a

b. Microclimate Factors

\_\_Re-reflected heat load
\_\_Frost pocket
\_\_Wind
Other \_\_\_\_\_

c. Sunlight Levels

\_\_Full sun (6 hrs. or more)
\_\_Partial sun or filtered light
\_\_Shade

d. Irrigation Levels

\_\_No supplemental irrigation
\_\_Automatic irrigation system
Irrigation amount and rate:
\_\_\_\_\_

4. Soil Factors

a. Range of pH Levels \_\_\_\_\_
(Note actual readings on sketch)

b. Texture

\_\_Clayey
\_\_Loamy
\_\_Sandy

c. Compaction Levels

\_\_Severely compacted
\_\_Moderately compacted
\_\_Somewhat compacted
\_\_Uncompactd

d. Drainage Characteristics

\_\_Presence of mottled soil
\_\_Low-lying topography
Indicator plants suggest site drainage:
\_\_wet \_\_well-drained \_\_dry
Percolation test results (in./hr.)
\_\_poorly drained (< 4"/hr.)
\_\_moderately drained (4"- 8"/hr.)
\_\_excessively drained (> 8"/hr.)

e. Other Soil Considerations

\_\_Indications of soil layer disturbance
\_\_Evidence of recent construction
\_\_Presence of construction debris
\_\_Noxious weeds present:
\_\_\_\_\_  
\_\_\_\_\_  
\_\_\_\_\_  
\_\_\_\_\_  
\_\_Evidence of excessive salt usage
\_\_Erosion of soil evident
\_\_Evidence of soil contamination
\_\_Usage that compacts soil

f. Specific Soil Problems

\_\_\_\_\_  
\_\_\_\_\_  
\_\_\_\_\_  
\_\_\_\_\_  
\_\_\_\_\_  
\_\_\_\_\_

5. Structural Factors

a. Limitations to above-ground space

\_\_Overhead wires (height: \_\_\_\_\_)
Proximity to buildings/structures:
Other \_\_\_\_\_

b. Limitations to below-ground space

\_\_Utilities marked and noted on sketch
Approximate rooting volume for site
Length: \_\_ Width: \_\_ Depth: \_\_



APPENDIX G

REFERENCE SHEETS

STANDARD TOWN DETAILS

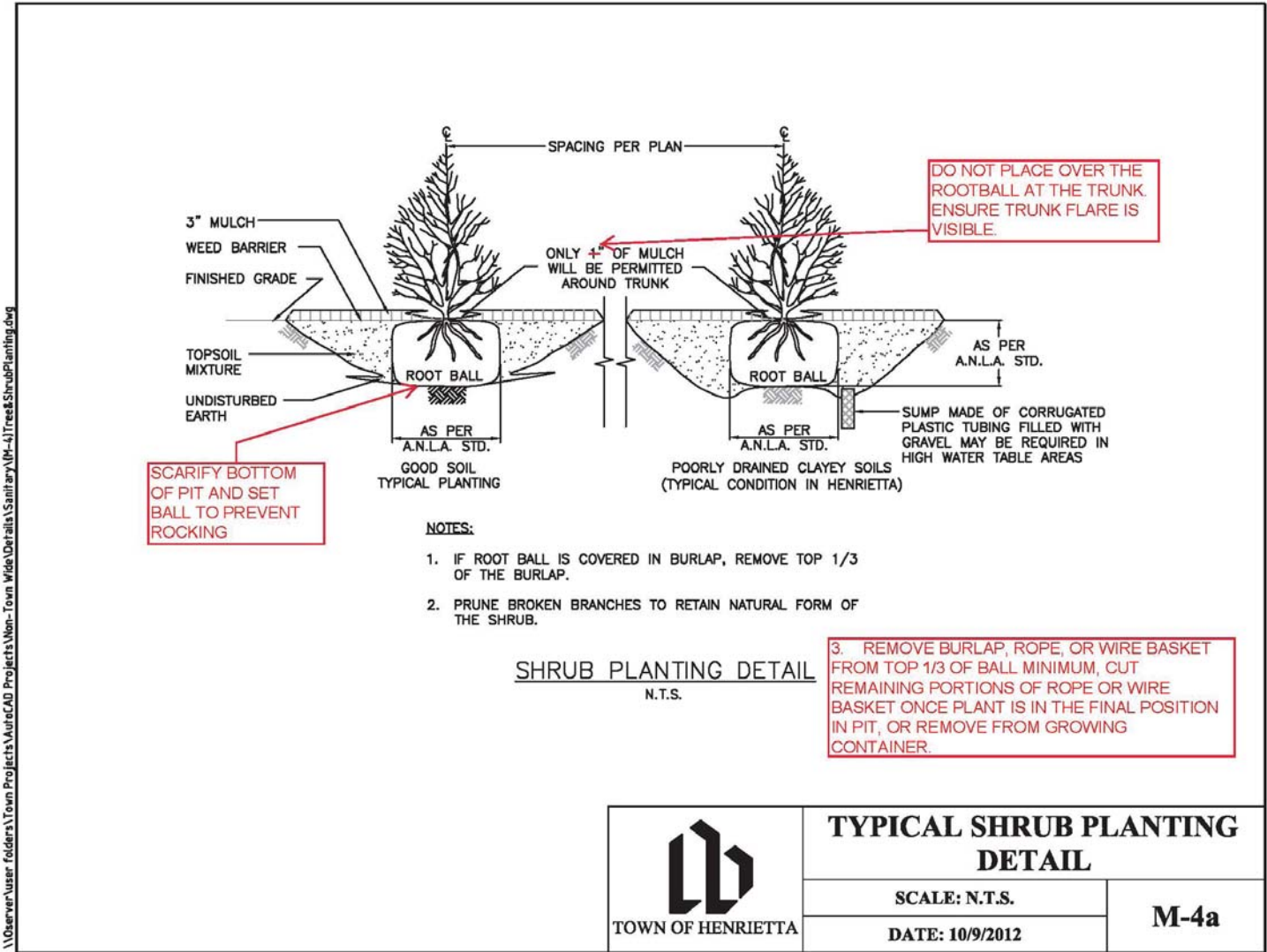

\\oserver\user\_folders\Town Projects\AutoCAD Projects\Wide Details\Sanitary\H-4\Trees&ShrubPlanting.dwg



\\0server\user\folders\Town Projects\AutCAD Projects\Wen-Town Wide\Details\Sanitary\M-4\Tree\Stru\Planting.dwg

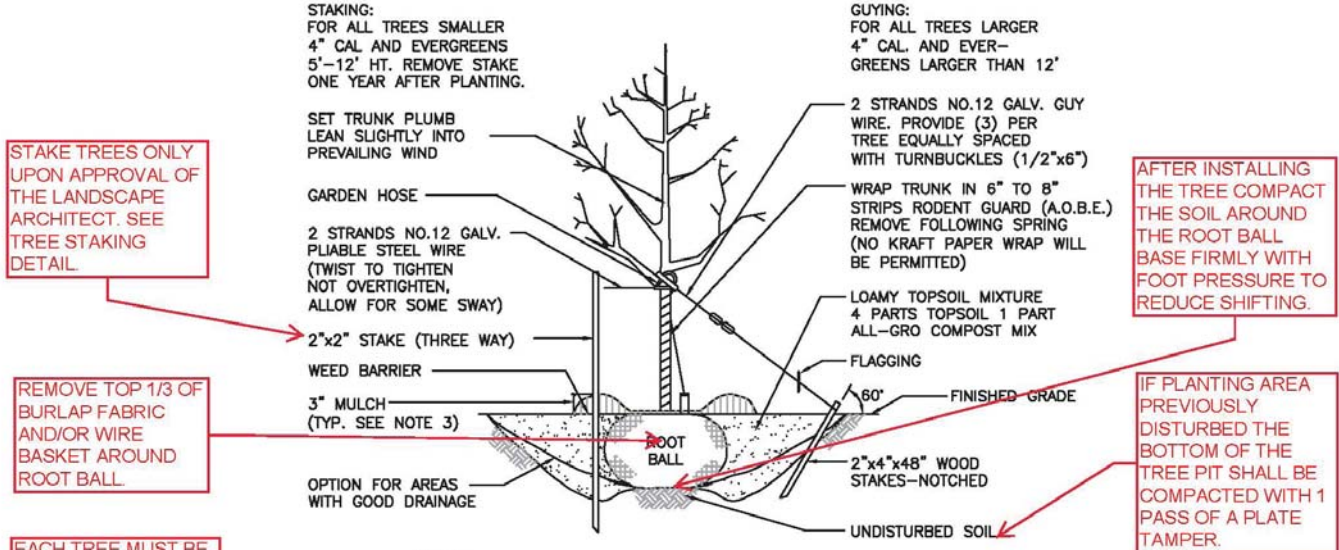

STAKE TREES ONLY UPON APPROVAL OF THE LANDSCAPE ARCHITECT. SEE TREE STAKING DETAIL.

REMOVE TOP 1/3 OF BURLAP FABRIC AND/OR WIRE BASKET AROUND ROOT BALL.

EACH TREE MUST BE PLANTED SUCH THAT THE TRUNK FLARE IS VISIBLE AT THE ROOT FLARE. TREES WHERE THIS IS NOT VISIBLE SHOULD BE REJECTED.

5. DO NOT HEAVILY PRUNE THE TREE AT PLANTING. DO NOT HEAVILY PRUNE THE TREE AT PLANTING, LEADERS, AND BROKEN OR DEAD BRANCHES. SOME INTERIOR TWIGS AND LATERAL BRANCHES MAY BE PRUNED; HOWEVER, DO NOT REMOVE THE TERMINAL BUDS OF BRANCHES THAT EXTEND TO THE EDGE OF THE CROWN.

AFTER INSTALLING THE TREE COMPACT THE SOIL AROUND THE ROOT BALL BASE FIRMLY WITH FOOT PRESSURE TO REDUCE SHIFTING.

IF PLANTING AREA PREVIOUSLY DISTURBED THE BOTTOM OF THE TREE PIT SHALL BE COMPACTED WITH 1 PASS OF A PLATE TAMPER.

- NOTES:**
1. USE 8" STAKES-DRIVE 48" BELOW GROUND.
  2. ROOT COLLAR TO BE SLIGHTLY ABOVE SURROUNDING GRADE.
  3. INSTALL 2" BARK MULCH. DO NOT PLACE MULCH IN CONTACT WITH TREE TRUNK.
  4. MULCH IS TO BE PLACED 3" TO 6" AWAY FROM THE TRUNK.

### TREE PLANTING DETAIL N.T.S.

6. MARK THE NORTH SIDE OF THE TREE AND ROTATE THE TREE TO FACE NORTH AT THE SITE WHEN POSSIBLE

 TOWN OF HENRIETTA	<b>TYPICAL TREE PLANTING DETAIL</b>	
	SCALE: N.T.S.	<b>M-4b</b>
DATE: 11/10/2011		

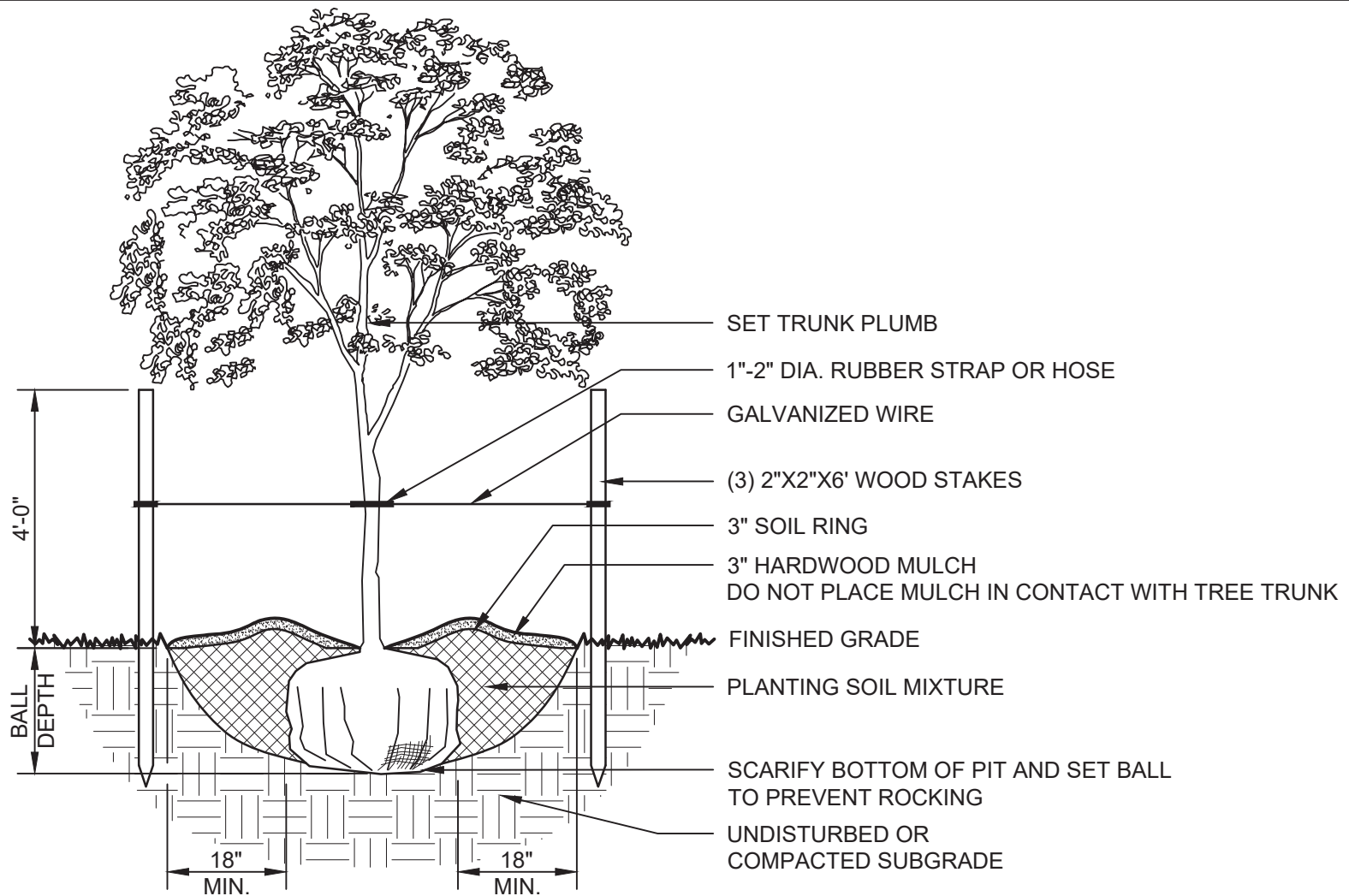

**NOTES**

1. REMOVE BURLAP, ROPE, OR WIRE BASKET FROM TOP 1/3 OF BALL MINIMUM, CUT REMAINING PORTIONS OF ROPE OR WIRE BASKET ONCE PLANT IS IN THE FINAL POSITION IN PIT.
2. TOP OF ROOT BALL SHALL BE SET FLUSH WITH SURROUNDING FINISHED GRADE. EACH TREE MUST BE PLANTED SUCH THAT THE TRUNK FLARE IS VISIBLE AT THE TOP OF THE ROOT BALL. DO NOT COVER TOP OF ROOT BALL WITH SOIL.
3. MARK THE NORTH SIDE OF THE TREE IN NURSERY AND ROTATE TREE TO FACE NORTH AT THE SITE WHERE POSSIBLE.



**DECIDUOUS TREE PLANTING**

NOT TO SCALE

WITH VERTICAL STAKES

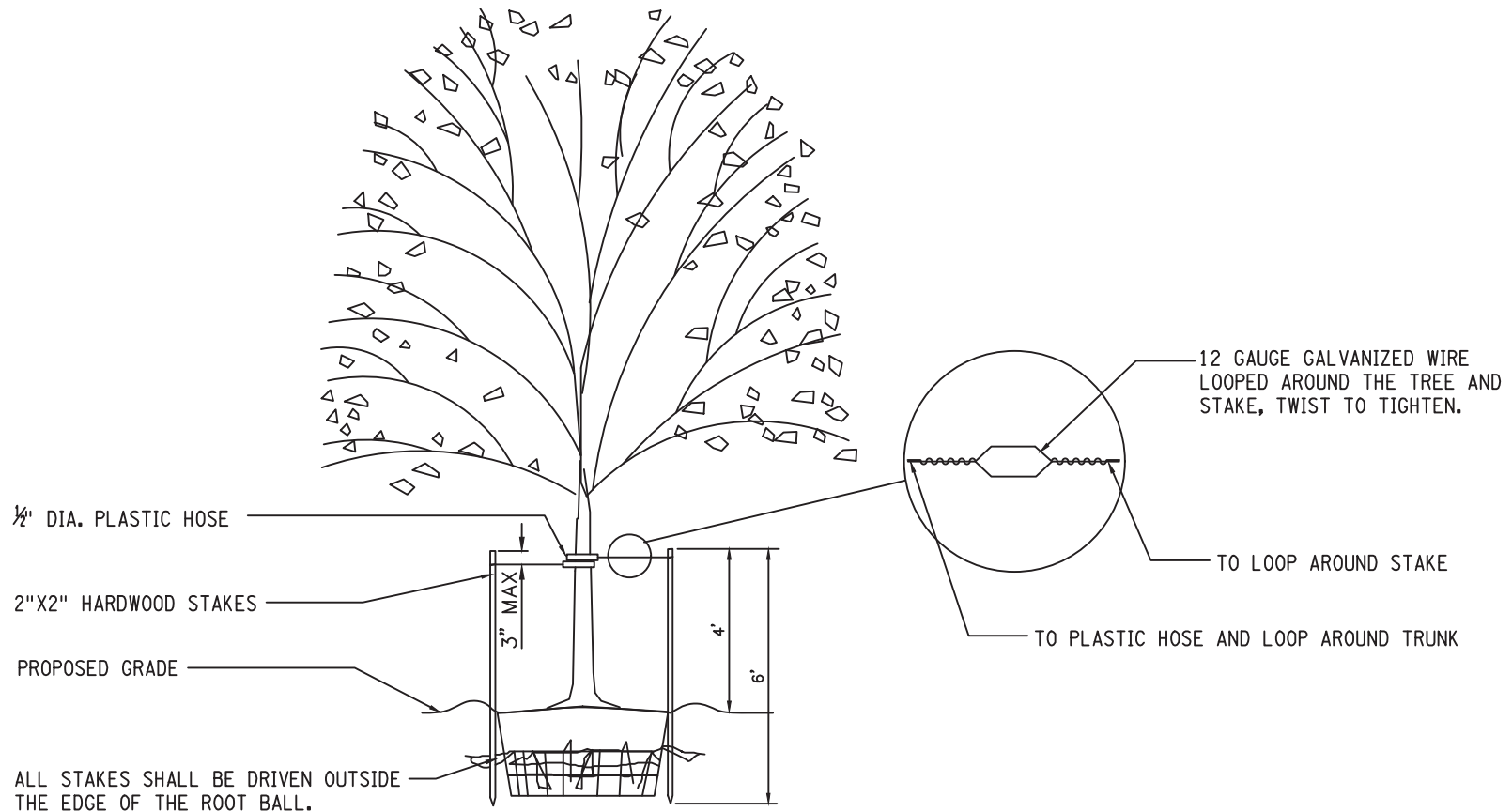

TREE STAKING NOTES:

1. TREES SHALL NOT BE STAKED UNLESS DIRECTED BY OR WITH THE APPROVAL OF THE LANDSCAPE ARCHITECT.
2. STAKES SHALL BE REMOVED AT THE END OF THE FIRST ENTIRE PLANTING SEASON AFTER PLANTING.
3. TIGHTEN WIRE OR CABLE ONLY ENOUGH TO KEEP IT FROM SLIPPING. ALLOW FOR SOME TRUNK MOVEMENT WITHIN THE PLASTIC HOSE.
4. THE PLASTIC HOSE SHALL BE 12" MINIMUM AND SHALL BE LONG ENOUGH TO ACCOMMODATE  $\frac{1}{2}$ " DIA. OF GROWTH AND BUFFER ALL BRANCHES FROM THE WIRE.
5. TUCK ANY LOOSE ENDS OF THE WIRE OR CABLE INTO THE WIRE WRAP SO THAT NO SHARP WIRE ENDS ARE EXPOSED.

TREE STAKING DETAIL

NOT TO SCALE



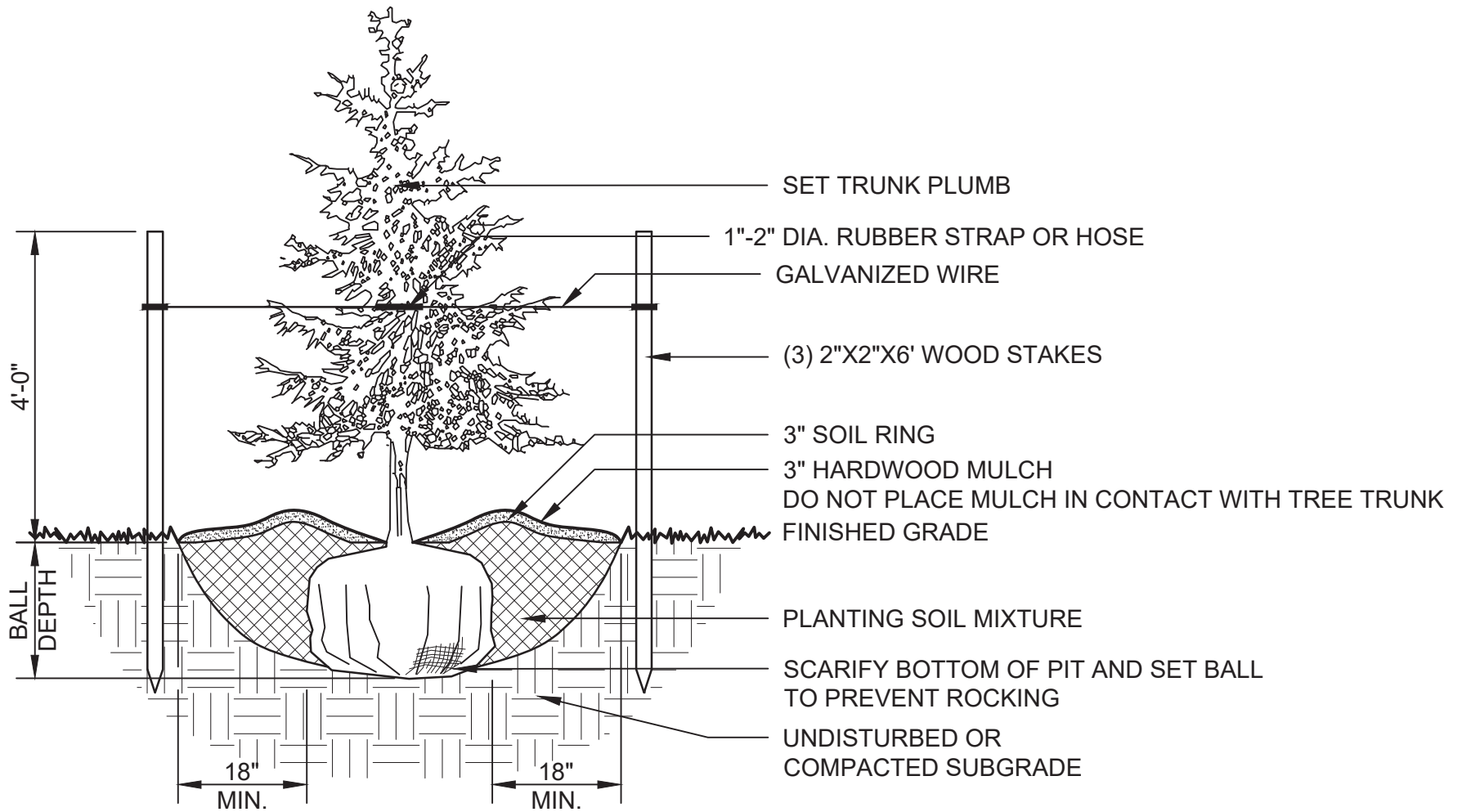

**NOTES**

1. REMOVE BURLAP, ROPE, OR WIRE BASKET FROM TOP 1/3 OF BALL MINIMUM, CUT REMAINING PORTIONS OF ROPE OR WIRE BASKET ONCE PLANT IS IN THE FINAL POSITION IN PIT.
2. TOP OF ROOT BALL SHALL BE SET FLUSH WITH SURROUNDING FINISHED GRADE. EACH TREE MUST BE PLANTED SUCH THAT THE TRUNK FLARE IS VISIBLE AT THE TOP OF THE ROOT BALL. DO NOT COVER TOP OF ROOT BALL WITH SOIL.
3. MARK THE NORTH SIDE OF THE TREE IN NURSERY AND ROTATE TREE TO FACE NORTH AT THE SITE WHERE POSSIBLE.

#  
L-100

**EVERGREEN TREE PLANTING**

NOT TO SCALE

WITH VERTICAL STAKES



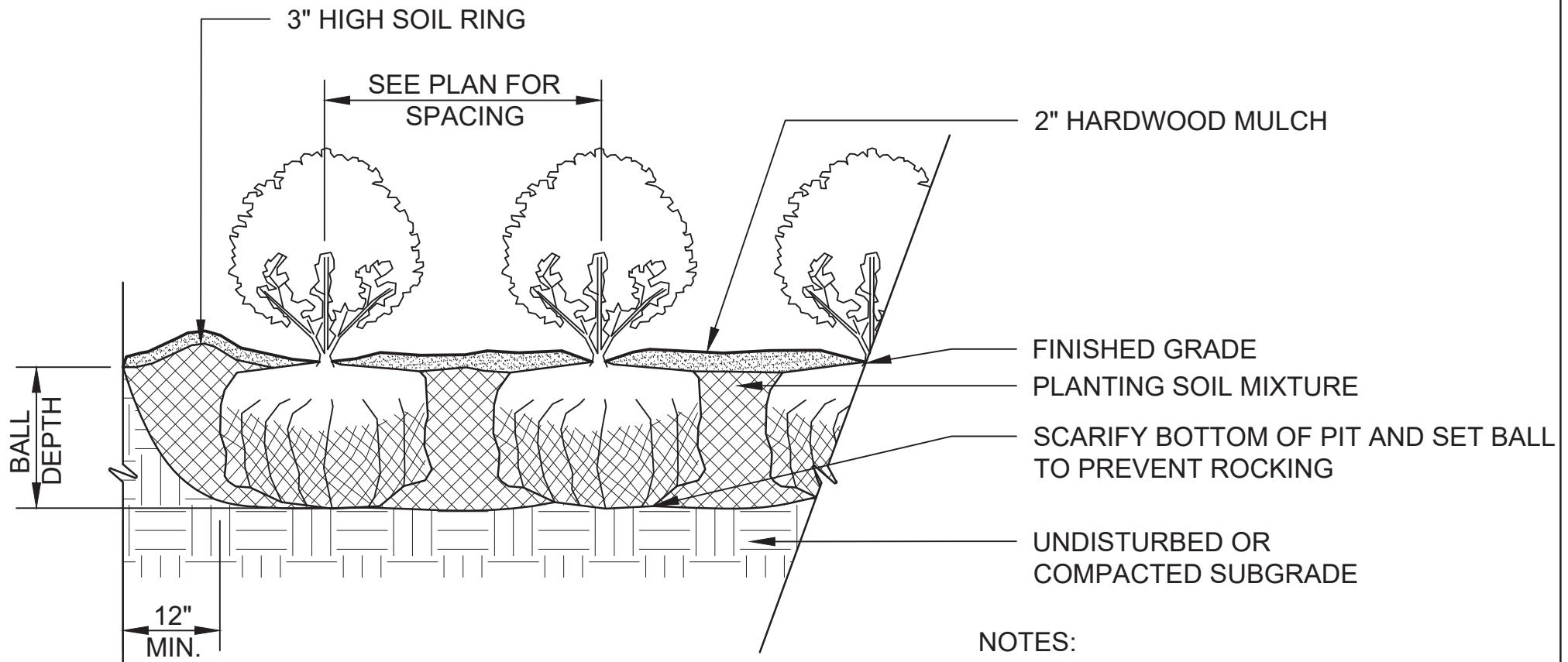

NOTES:

1. REMOVE BURLAP, ROPE, OR WIRE BASKET FROM TOP  $\frac{1}{3}$  OF BALL MINIMUM, CUT REMAINING PORTIONS OF ROPE OR WIRE BASKET ONCE PLANT IS IN THE FINAL POSITION IN PIT OR REMOVE FROM GROWING CONTAINER.

#  
L-100

# SHRUB MASS PLANTING

NOT TO SCALE

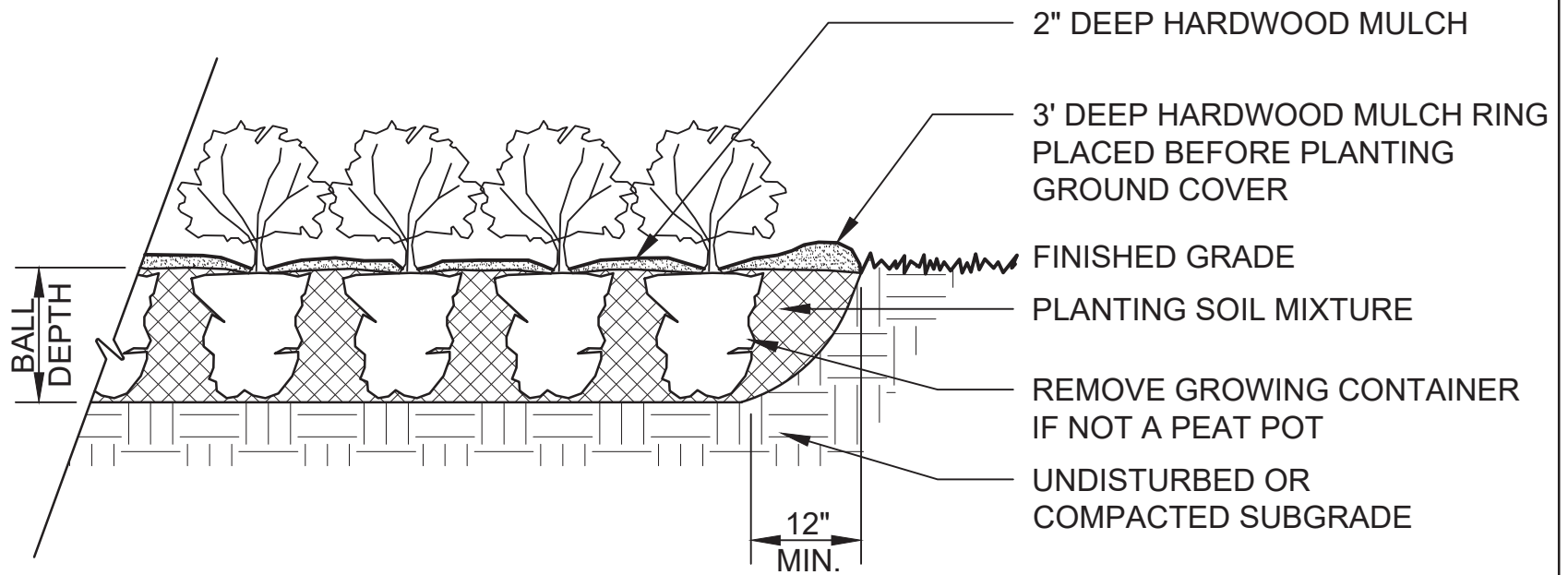

#  
L-100

## PERENNIAL AND GROUND COVER PLANTING

NOT TO SCALE

WITH CONTINUOUS PLANT BED

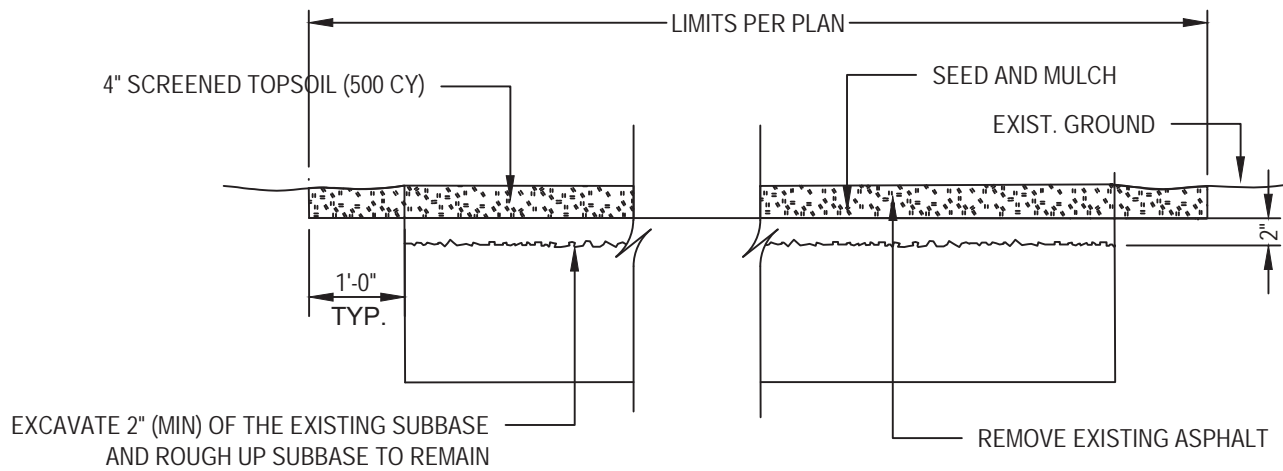

#  
L-100

# LAWN RESTORATION

NOT TO SCALE

## **PLANTING NOTES**

1. CONTRACTOR SHALL VERIFY LOCATIONS OF ALL EXISTING AND PROPOSED UTILITY LOCATIONS PRIOR TO INSTALLING ANY PLANT MATERIAL.
2. ALL PLANT MATERIALS SHALL CONFORM THE THE GUIDELINES ESTABLISHED BY THE CURRENT 'AMERICAN STANDARD FOR NURSERY STOCK,' PUBLISHED BY THE AMERICAN NURSERY AND LANDSCAPE ASSOCIATION.
3. ALL PLANTS SHALL BE DELIVERED AS SPECIFIED IN THE PLANT LIST. NO CONTAINER BOUND STOCK WILL BE ACCEPTED IF IT IS ROOT BOUND. ALL ROOT WRAPPING MATERIAL MADE OF SYNTHETICS OR PLASTICS SHALL BE REMOVED ENTIRELY AT TIME OF PLANTING.
4. WITH CONTAINER GROWN STOCK, THE CONTAINER SHALL BE REMOVED AND THE CONTAINER BALL SHALL BE LOOSENED BY SCARIFYING THE SURFACE OF THE BALL VERTICALLY IN THREE LOCATIONS TO ENCOURAGE IMMEDIATE ROOT GROWTH.
5. ALL LOCATION OF TREES AND SHRUBS SHALL BE STAKE ONE DAY PRIOR TO PLANTING INSTALLATIONS, FOR APPROVAL BY THE PROJECT LANDSCAPE ARCHITECT.
6. ALL PLANTS SHALL BE SET PLUMB UNLESS DIRECTED OTHERWISE.
7. ALL SHRUB BEDS AND PLANTING AREAS SHALL RECEIVE MINIMUM 2" DEPTH OF SHREDDDED HARDWOOD MULCH AS SPECIFIED.
8. DO NOT HEAVILY PRUNE TREES AT PLANTING. INTERIOR TWIGS AND LATERAL BRANCHES MAY BE PRUNED; HOWEVER, DO NOT REMOVE THE TERMINAL BUDS OF BRANCHES THAT EXTEND TO THE EDGE OF THE CROWN.
9. ALL PLANTS SHALL BE WATERED THOROUGHLY TWICE DURING THE FIRST 24 HOUR PERIOD AFTER PLANTING. ALL PLANTS (INCLUDING PORTABLE DRIP IRRIGATION SYSTEMS AROUND TREES) SHALL THEN BE WATERED WEEKLY, AT A MINIMUM, DURING THE FIRST GROWING SEASON.
10. ALL TREES SHALL RECEIVE A PORTABLE DRIP IRRIGATION SYSTEM DURING THE FIRST GROWING SEASON.
11. ALL PLANTING BEDS SHALL BE EXCAVATED TO A MINIMUM DEPTH OF 2'. PLANTING BEDS SHALL RECEIVE SPECIFIED PLANTING SOIL MIXTURE TO A MINIMUM DEPTH OF 2'.
12. MULCH SHALL NOT CONTAIN ANY PLANT SYSTEMS.
13. THE CONTRACTOR SHALL INSTALL TREE AND BACKFILL THE HOLE WITH SPECIFIED PLANTING SOIL MIXTURE COMPACTING IN 8" LIFTS TO ENSURE THE SOIL IS FIRM AND PROVIDES SUPPORT FOR THE TREE.
14. PLANTING AREAS SHALL NOT BE GRADED TOWARD PERVIOUS PAVEMENT.

## **TREE STAKING NOTES**

1. TREES SHALL NOT BE STAKED UNLESS DIRECTED BY OR WITH THE APPROVAL OF LANDSCAPE ARCHITECT.
2. ALL STAKES SHALL BE DRIVEN OUTSIDE THE EDGE OF THE ROOT BALL.
3. STAKES SHALL BE REMOVED AT THE END OF THE FIRST ENTIRE PLANTING SEASON AFTER PLANTING.
4. TIGHTEN WIRE OR CABLE ONLY ENOUGH TO KEEP IT FROM SLIPPING. ALLOW FOR SOME TRUNK MOVEMENT WITH THE PLASTIC HOSE.
5. THE PLASTIC HOSE SHALL BE 12" MINIMUM AND SHALL BE LONG ENOUGH TO ACCOMMODATE 1½" DIA. OF GROWTH AND BUFFER ALL BRANCHES FROM WIRE.
6. ALL WIRE SHALL BE 12 GAUGE GALVANIZED WIRE AND SHALL BE LONG ENOUGH TO LOOP AROUND THE TREE AND STAKE (2 STRANDS PER STAKE), TWIST TO TIGHTEN.
7. TUCK ANY LOOSE ENDS OF THE WIRE OR CABLE INTO THE WIRE WRAP SO THAT NOW SHARP WIRE ENDS ARE EXPOSED.



APPENDIX G

# REFERENCE SHEETS

## NYS STANDARDS AND SPECIFICATIONS FOR EROSION AND SEDIMENT CONTROL



## STANDARD AND SPECIFICATIONS FOR MULCHING



### Definition and Scope

Applying coarse plant residue or chips, or other suitable materials, to cover the soil surface to provide initial erosion control while a seeding or shrub planting is establishing. Mulch will conserve moisture and modify the surface soil temperature and reduce fluctuation of both. Mulch will prevent soil surface crusting and aid in weed control. Mulch can also be used alone for temporary stabilization in non-growing months. Use of stone as a mulch could be more permanent and should not be limited to non-growing months.

### Conditions Where Practice Applies

On soils subject to erosion and on new seedings and shrub plantings. Mulch is useful on soils with low infiltration rates by retarding runoff.

### Criteria

Site preparation prior to mulching requires the installation of necessary erosion control or water management practices and drainage systems.

Slope, grade and smooth the site to fit needs of selected mulch products.

Remove all undesirable stones and other debris to meet the needs of the anticipated land use and maintenance required.

Apply mulch after soil amendments and planting is accomplished or simultaneously if hydroseeding is used.

Select appropriate mulch material and application rate or material needs. Hay mulch shall not be used in wetlands or in areas of permanent seeding. Clean straw mulch is preferred alternative in wetland application. Determine local availability.

Select appropriate mulch anchoring material.

NOTE: The best combination for grass/legume establishment is straw (cereal grain) mulch applied at 2 ton/acre (90 lbs./1000sq.ft.) and anchored with wood fiber mulch (hydromulch) at 500 – 750 lbs./acre (11 – 17 lbs./1000 sq. ft.). The wood fiber mulch must be applied through a hydroseeder immediately after mulching.





**Table 4.2  
Guide to Mulch Materials, Rates, and Uses**

Mulch Material	Quality Standards	per 1000 Sq. Ft.	per Acre	Depth of Application	Remarks
Wood chips or shavings	Air-dried. Free of objectionable coarse material	500-900 lbs.	10-20 tons	2-7"	Used primarily around shrub and tree plantings and recreation trails to inhibit weed competition. Resistant to wind blowing. Decomposes slowly.
Wood fiber cellulose (partly digested wood fibers)	Made from natural wood usually with green dye and dispersing agent	50 lbs.	2,000 lbs.	—	Apply with hydromulcher. No tie down required. Less erosion control provided than 2 tons of hay or straw.
Gravel, Crushed Stone or Slag	Washed; Size 2B or 3A—1 1/2"	9 cu. yds.	405 cu. yds.	3"	Excellent mulch for short slopes and around plants and ornamentals. Use 2B where subject to traffic. (Approximately 2,000 lbs./cu. yd.). Frequently used over filter fabric for better weed control.
Hay or Straw	Air-dried; free of undesirable seeds & coarse materials	90-100 lbs. 2-3 bales	2 tons (100-120 bales)	cover about 90% surface	Use small grain straw where mulch is maintained for more than three months. Subject to wind blowing unless anchored. Most commonly used mulching material. Provides the best micro-environment for germinating seeds.
Jute twisted yarn	Undyed, unbleached plain weave. Warp 78 ends/yd., Weft 41 ends/yd. 60-90 lbs./roll	48" x 50 yds. or 48" x 75 yds.	—	—	Use without additional mulch. Tie down as per manufacturers specifications. Good for center line of concentrated water flow.
Excelsior wood fiber mats	Interlocking web of excelsior fibers with photodegradable plastic netting	4' x 112.5' or 8' x 112.5'	—	—	Use without additional mulch. Excellent for seeding establishment. Anchor as per manufacturers specifications. Approximately 72 lbs./roll for excelsior with plastic on both sides. Use two sided plastic for centerline of waterways.
Straw or coconut fiber, or combination	Photodegradable plastic net on one or two sides	Most are 6.5 ft. x 3.5 ft.	81 rolls	—	Designed to tolerate higher velocity water flow, centerlines of waterways, 60 sq. yds. per roll.





**Table 4.3  
Mulch Anchoring Guide**

Anchoring Method or Material	Kind of Mulch to be Anchored	How to Apply
1. Peg and Twine	Hay or straw	After mulching, divide areas into blocks approximately 1 sq. yd. in size. Drive 4-6 pegs per block to within 2" to 3" of soil surface. Secure mulch to surface by stretching twine between pegs in criss-cross pattern on each block. Secure twine around each peg with 2 or more tight turns. Drive pegs flush with soil. Driving stakes into ground tightens the twine.
2. Mulch netting	Hay or straw	Staple the light-weight paper, jute, wood fiber, or plastic nettings to soil surface according to manufacturer's recommendations. Should be biodegradable. Most products are not suitable for foot traffic.
3. Wood cellulose fiber	Hay or straw	Apply with hydroseeder immediately after mulching. Use 500 lbs. wood fiber per acre. Some products contain an adhesive material ("tackifier"), possibly advantageous.
4. Mulch anchoring tool	Hay or straw	Apply mulch and pull a mulch anchoring tool (blunt, straight discs) over mulch as near to the contour as possible. Mulch material should be "tucked" into soil surface about 3".
5. Tackifier	Hay or straw	Mix and apply polymeric and gum tackifiers according to manufacturer's instructions. Avoid application during rain. A 24-hour curing period and a soil temperature higher than 45 <sup>o</sup> Fahrenheit are required.



## STANDARD AND SPECIFICATIONS FOR SOIL RESTORATION



### Definition & Scope

The decompaction of areas of a development site or construction project where soils have been disturbed to recover the original properties and porosity of the soil; thus providing a sustainable growth medium for vegetation, reduction of runoff and filtering of pollutants from stormwater runoff.

### Conditions Where Practice Applies

Soil restoration is to be applied to areas whose heavy construction traffic is done and final stabilization is to begin. This is generally applied in the cleanup, site restoration, and landscaping phase of construction followed by the permanent establishment of an appropriate ground cover to maintain the soil structure. Soil restoration measures should be applied over and adjacent to any runoff reduction practices to achieve design performance.



### Design Criteria

1. Soil restoration areas will be designated on the plan views of areas to be disturbed.

2. Soil restoration will be completed in accordance with Table 4.6 on page 4.53.

### Specification for Full Soil Restoration

During periods of relatively low to moderate subsoil moisture, the disturbed subsoils are returned to rough grade and the following Soil Restoration steps applied:

1. Apply 3 inches of compost over subsoil. The compost shall be well decomposed (matured at least 3 months), weed-free, organic matter. It shall be aerobically composted, possess no objectionable odors, and contain less than 1%, by dry weight, of man-made foreign matter. The physical parameters of the compost shall meet the standards listed in Table 5.2 - Compost Standards Table, except for "Particle Size" 100% will pass the 1/2" sieve. **Note: All biosolids compost produced in New York State (or approved for importation) must meet NYS DEC's 6 NYCRR Part 360 (Solid Waste Management Facilities) requirements. The Part 360 requirements are equal to or more stringent than 40 CFR Part 503 which ensure safe standards for pathogen reduction and heavy metals content.**



2. Till compost into subsoil to a depth of at least 12 inches using a cat-mounted ripper, tractor mounted disc, or tiller, to mix and circulate air and compost into the subsoil.
3. Rock-pick until uplifted stone/rock materials of four inches and larger size are cleaned off the site.
4. Apply topsoil to a depth of 6 inches.
5. Vegetate as required by the seeding plan. Use appropriate ground cover with deep roots to maintain the soil structure.
6. Topsoil may be manufactured as a mixture of a mineral component and organic material such as compost.



- Compost filter socks shall be anchored in earth with 2" x 2" wooden stakes driven 12" into the soil on 10 foot centers on the centerline of the sock. On uneven terrain, effective ground contact can be enhanced by the placement of a fillet of filter media on the disturbed area side of the compost sock.
- All specific construction details and material specifications shall appear on the erosion and sediment control constructions drawings when compost filter socks are included in the plan.
- Socks shall be inspected weekly and after each runoff event. Damaged socks shall be repaired in the manner required by the manufacturer or replaced within 24 hours of inspection notification.
- Biodegradable filter socks shall be replaced after 6 months; photodegradable filter socks after 1 year. Polypropylene socks shall be replaced according to the manufacturer's recommendations.

### Maintenance

- Traffic shall not be permitted to cross filter socks.
- Accumulated sediment shall be removed when it reaches half the above ground height of the sock and disposed of in accordance with the plan.
- Upon stabilization of the area contributory to the sock, stakes shall be removed. The sock may be left in place and vegetated or removed in accordance with the stabilization plan. For removal the mesh can be cut and the compost spread as an additional mulch to act as a soil supplement.

### Table 5.1 - Compost Sock Fabric Minimum Specifications Table

Material Type	3 mil HDPE	5 mil HDPE	5 mil HDPE	Multi-Filament Polypropylene (MFPP)	Heavy Duty Multi-Filament Polypropylene (HDMFPP)
Material Characteristics	Photodegradable	Photodegradable	Biodegradable	Photodegradable	Photodegradable
Sock Diameters	12" 18"	12" 18" 24" 32"	12" 18" 24" 32"	12" 18" 24" 32"	12" 18" 24" 32"
Mesh Opening	3/8"	3/8"	3/8"	3/8"	1/8"
Tensile Strength		26 psi	26 psi	44 psi	202 psi
Ultraviolet Stability % Original Strength (ASTM G-155)	23% at 1000 hr.	23% at 1000 hr.		100% at 1000 hr.	100% at 1000 hr.
Minimum Functional Longevity	6 months	9 months	6 months	1 year	2 years

### Table 5.2 - Compost Standards Table

Organic matter content	25% - 100% (dry weight)
Organic portion	Fibrous and elongated
pH	6.0 – 8.0
Moisture content	30% - 60%
Particle size	100% passing a 1" screen and 10 - 50% passing a 3/8" screen
Soluble salt concentration	5.0 dS/m (mmhos/cm) maximum



### APPENDIX H

# GLOSSARY

## SECTION 2.1

### ***Wayfinding***

A navigational set of tools and signs that connect transportation routes physically and visually. Can be a mix of signs and markers.

### ***Sightlines***

The focus of the viewer. Can generate a sightline towards a landmark, important feature, or certain orientation to allow the viewer to navigate through a place, or focus on something that's important. Structures, plants, or objects seem to frame a view to block certain features from a person's view through spread or height that hone the focus on this certain place.

## SECTION 2.2

### ***Cation exchange***

Capacity for soil to undergo this process determines the ability for the soil to retain nutrients.

### ***Permeability***

Ability for water to percolate, or pass through, a surface.

### ***Nutrient capacity***

Ability for soil to hold and absorb nutrients.

### ***Moisture Retention***

Ability for the soil to hold water for a period of time to allow the soil to filter metals, chemicals, and nutrients before water returns to water table.

### ***Cut and Fill Soil***

Removal and placement of soil; balanced quantities can even out so that removed material can be re-used on site.

### ***Drainage patterns***

Existing flow to certain bodies of water or areas.

### ***Designed landforms***

Modified and re-graded through construction; not naturally existing.



### SECTION 2.3

#### ***Invasive species***

“Species non-native to an ecosystem that is likely to cause economic or environmental harm or harm to human health,” regulated by the NYSDEC. These species may be likely to take over and cause disruption to a native population serving a niche that balances the roles of each organism in an ecosystem.

#### ***Native species***

A species that has lived and thrived in a particular ecosystem or region without human intervention over hundreds or thousands of years.

#### ***Prohibited invasive species***

Invasive species prohibited for possession, transport, importation, sale, purchase, and introduction throughout New York State to reduce biological pollution, infestations, harm, and spread (NYSDEC).

#### ***Non-native species***

A human introduced species existing in a particular ecosystem or region that it was not previously found.

#### ***Plant community***

Collection of plant species well adapted to certain conditions that coexist.

#### ***Cultivar species***

Species derived from a naturally occurring species that has been horticulturally modified with certain desirable traits.

#### ***Species composition***

Types of species in a grouping or collection.

### SECTION 2.4

#### ***Stormwater Management***

“Activities or structural improvements that help reduce the quantity and improve the quality of stormwater runoff” (NYS Department of Transportation).

#### ***Green infrastructure***

A patchwork of natural areas that provides habitat, flood protection, cleaner air, and cleaner water; on site, stormwater management systems that mimic nature soak up and store water (US EPA).

#### ***Surface composition***

Proportion of certain materials to other materials at a given site, for example, the ratio of lawn cover to asphalt pavement in square feet.

#### ***Hydric tolerance***

Species adapted to survive in areas of moisture and saturation.



### SECTION 2.5

#### ***Albedo***

Measure of sun light reflected off of a material surface. Low amounts are reflected by pavements that are dark, since they absorb sunlight, and high amounts are reflected by pavements that are light.

#### ***Solar reflective index***

UV rays reflected by a surface; indicates how hot a surface will become with sunlight and how long this heat will persist.

### SECTION 2.7

#### ***Infill planting***

To replace dead or damaged plant material with new plant material to build up the landscape design, can be just replacing previous material or introducing new material.

AS ACTED UPON DURING A DULY NOTICED OPEN SPECIAL MEETING OF THE TOWN BOARD OF THE TOWN OF HENRIETTA, COUNTY OF MONROE, STATE OF NEW YORK, HELD AT THE HENRIETTA TOWN HALL AT 475 CALKINS ROAD, HENRIETTA, NEW YORK ON NOVEMBER 13, 2019 AT 7:00 P.M.

RESOLUTION #25-318/2019

On Motion of  
Councilman Barley

Seconded by  
Councilman Adair

WHEREAS, on April 11, 2018 the Town of Henrietta, per Resolution #8-137/2018, authorized Barton & Loguidice, DPC to develop landscaping guideline standards for development, and

WHEREAS, during said study a Committee was formed and provided input in the development of the landscaping guidelines, and

WHEREAS, a *Landscape Guidelines, Standards for Development* has been prepared.

THEREFORE, BE IT RESOLVED, that the *Landscape Guidelines, Standards for Development* is accepted by the Town Board of the Town of Henrietta and said Plan is available for public review at the Town Clerk's Office in the Town Hall.

Duly put to a vote:

Councilman Page	voting	Aye
Councilman Adair	voting	Aye
Councilman Barley	voting	Aye
Councilman Stafford	voting	Aye
Supervisor Schultz	voting	Aye

Carried