

\\0server\user folders\Town Projects\AutoCAD Projects\Non-Town Wide\Details\Storm\ST-18\InstallationUnderPavement.dwg

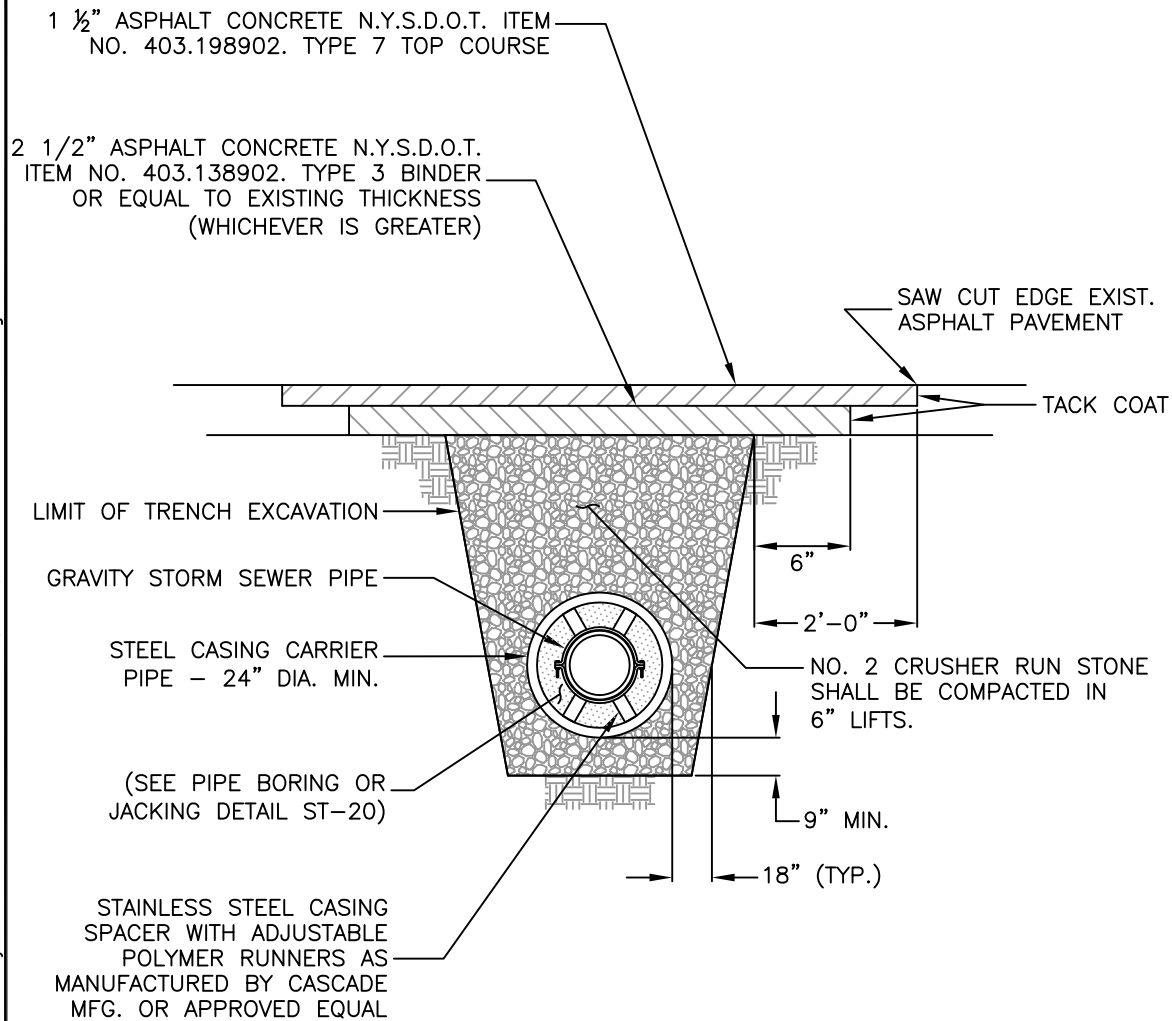

OPEN TRENCH METHOD

NOTES:

1. THE CONTRACTOR SHALL OBTAIN ALL NECESSARY HIGHWAY PERMITS TO COMPLETE THE WORK FROM N.Y.S.D.O.T., D.P.W., M.C.D.O.T., AND TOWN OF HENRIETTA. ALL WORK SHALL MEET THE APPROVAL OF THE N.Y.S.D.O.T. RESIDENT ENGINEER, M.C.D.O.T. ENGINEERS, OR TOWN ENGINEER.
2. ALL APPROVED HIGHWAY WORK PERMITS SHALL BE OBTAINED FROM THE PROPER AGENCIES PRIOR TO COMMENCING OF WORK. HAVING JURISDICTION HIGHWAY WORK PERMIT MUST BE ON-SITE AT ALL TIMES.
3. ASPHALT PAVEMENT SHALL EQUAL THE THICKNESS OF EXISTING PAVEMENT, BUT NOT LESS THAN SHOWN ON DETAIL.
4. STEEL CASING CARRIER PIPE SHALL BE CONTINUOUSLY WELDED STEEL PIPE PER A.S.T.M. A-139 GRADE B WITH A MINIMUM YIELD STRENGTH OF 36,000 PSI, A MINIMUM TENSILE STRENGTH OF 60,000 PSI, & A MINIMUM WALL THICKNESS OF 0.375" (3/8").
5. BOTH CASING PIPE ENDS SHALL BE BULLHEAD WITH BRICK MASONRY.
6. STEEL CASING WILL NOT BE REQUIRED UNDER TOWN OF HENRIETTA ROADS, UNLESS ORDERED BY THE HIGHWAY SUPERINTENDENT.
7. IF DETERMINED ACCEPTABLE BY TOWN ENGINEER, CONTRACTOR MAY SUBSTITUTE BANDED TIMBERS (SEE DETAIL NO. ST-20 ALTERNATE A) IN LIEU OF STAINLESS STEEL CASING SPACERS.

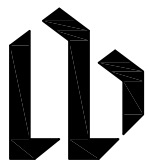
 TOWN OF HENRIETTA	INSTALLATION UNDER ROADWAY PAVEMENT	
	SCALE: N.T.S.	ST-19
	DATE: 11/15/2011	