

\\server\user folders\Town Projects\AutoCAD Projects\Non-Town Wide\Details\Sanitary\SA-11\NewManholeExist\Sewer.dwg

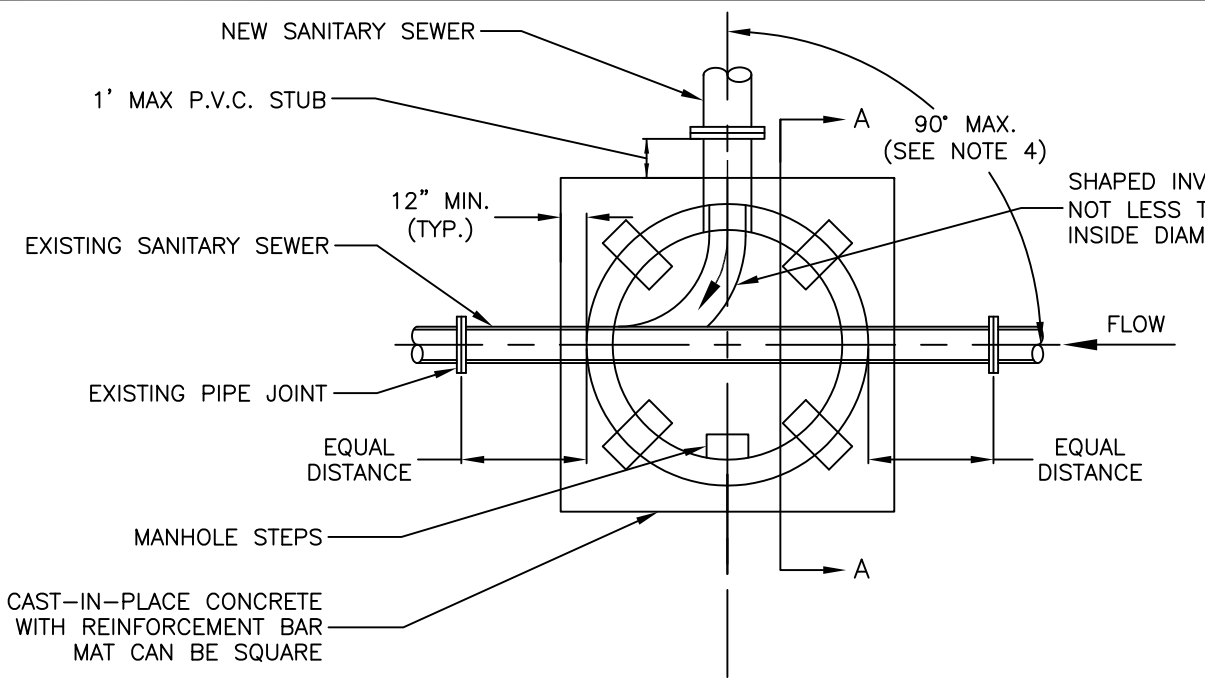

PLAN VIEW

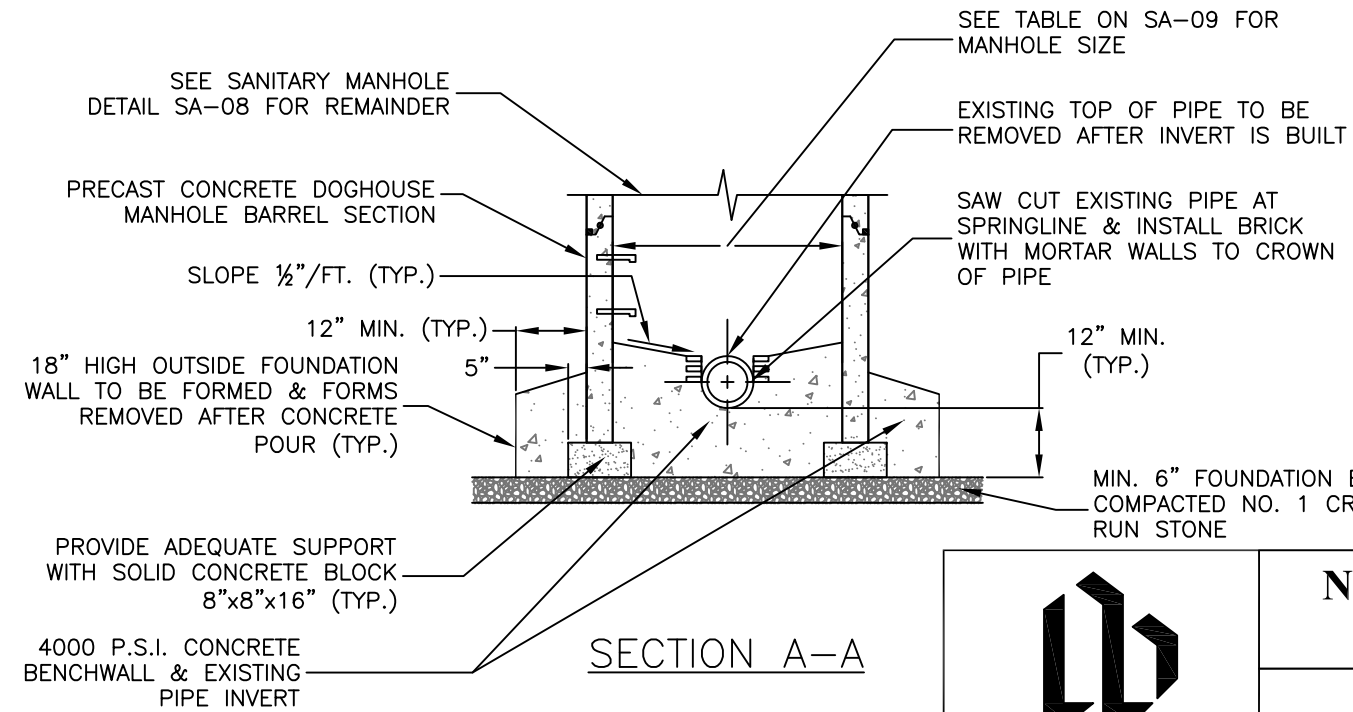

SECTION A-A

NOTES:

1. CONTRACTOR TO BUILD NEW MANHOLE EQUAL DISTANCE BETWEEN EXISTING PIPE JOINTS ON EXISTING SANITARY SEWER.
2. EXISTING PIPE SHALL BE THOROUGHLY CLEANED AND ADEQUATELY SUPPORTED PRIOR TO POURING CONCRETE FOR BASE.
3. REINFORCEMENT TO BE DETERMINED BY DESIGN CALCULATIONS AND SUBMITTED TO TOWN ENGINEERING DEPARTMENT FOR REVIEW. USE NO. 5 BARS, 12" O.C. EACH WAY MINIMUM.
4. PIPE ENTERING INTO SANITARY MANHOLE SHALL NOT EXCEED 90° ALIGNMENT AGAINST EXISTING SANITARY SEWER MAIN FLOW.
5. THE INTERIOR OF SANITARY MANHOLE BASE SECTION TO BE 12" MIN. ABOVE THE HIGHEST PIPE. THE INVERT AND BENCHWALL SHALL BE COATED WITH 2 COATS OF SIKAGARD 62. ALL OTHER SURFACES SHALL HAVE 2 COATS KOPPERS SUPER SERVICE BLACK.
6. EXISTING SANITARY SEWER SHALL BE TELEVISED BEFORE AND AFTER CONSTRUCTION OF NEW SANITARY MANHOLE.

 TOWN OF HENRIETTA	NEW MANHOLE CONSTRUCT OVER EXISTING SEWER	
	SCALE: N.T.S.	SA-11
DATE: 11/15/2011		