

\\Oserver\user\_folders\Town Projects\AutoCAD Projects\Non-Town Wide\Details\Sanitary\ISA-17\Deflection TestingMandrel.dwg

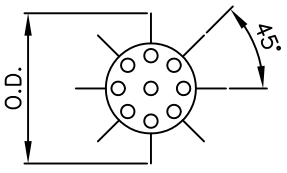

8 RUNNER FOR  
6-8 AND 10 INCH

STAMPED IDENTIFICATION  
INCLUDING SERIAL NUMBER  
ON RUNNERS.

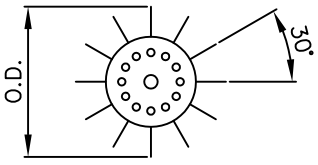
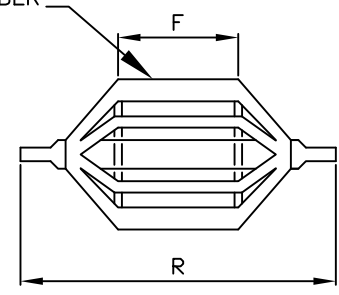

12 RUNNER FOR  
12-15 AND 18 INCH

END RUNNERS 1/4 x 3/4"  
RUNNERS 1/4" x 1 1/4"  
ALUM. MACHINED  
TO SIZE

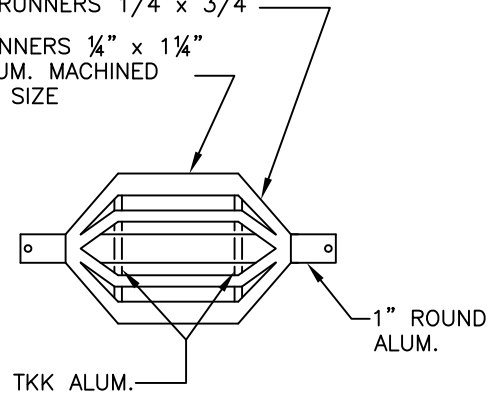

**NOTE:**

THE OUTSIDE DIAMETER OF THE MANDREL IS DETERMINED BY THE ACTUAL PIPE INTERNAL DIAMETER (AS CERTIFIED BY THE PIPE MANUFACTURER) MINUS 5% ALLOWABLE DEFLECTION. THE ALLOWABLE TOLERANCE OF THE MANDREL OUTSIDE DIAMETER IS +0.000, -0.040 INCHES.

NOMINAL PIPE DIA.	F	R	NUMBERS OF RUNNERS
6"	6 1/2"	15"	8
8"	6 1/2"	17"	8
10"	8"	21"	8
12"	9"	25"	12
15"	10"	27"	12
18"	10"	27"	12
COM. MEASURE ±1/16"			

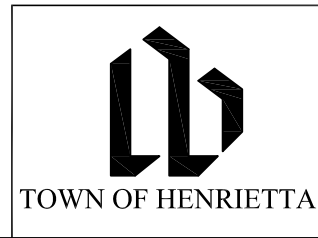

<b>DEFLECTION TESTING MANDREL</b>	
SCALE: N.T.S.	<b>SA-17</b>
DATE: 11/15/2011	